



RUSCHMEYER R 90 230 RG

GRONDCURSUS

Programma:

- * General construction: Strength - laminair flow wing (dirt!)
controls - elevator + trim
- * Flap system: Pitch trim interconnect.
- * Power plant: Fuel injection - cooling
Propellor system - RPM-indication
Limitations - Power settings
*IO-540 ~ 8860 cc
E = 2.5
231 HP @ 2900 RPM
4-blade prop.
Landing gear*
- * Electrical system: Layout - Circuit Breakers/switches
Busses - Failures.
- * Avionics: Compass System - H.S.I. - Auto Pilot
Electrical trim - Stick switches.
Layout & control - Failures.
Pre-Flight checks.
- * Landing Gear system: Layout - indication - failures
Brakes & parking brake.
- * Fuel System: Layout - tanks - fuel quantity
Fuel Flow Computer.
- * Limitations: Va - Glide/Climb speeds.
- * Performance: T/O & Landing - Climb - Cruise
Charts & Policy.
- * Weight & Balance: General discussion
- * Emergency Procedures: General discussion

CONTROLS

- * EFFECT OF SPRINGS
- * EFFECT OF DOWNSPRING

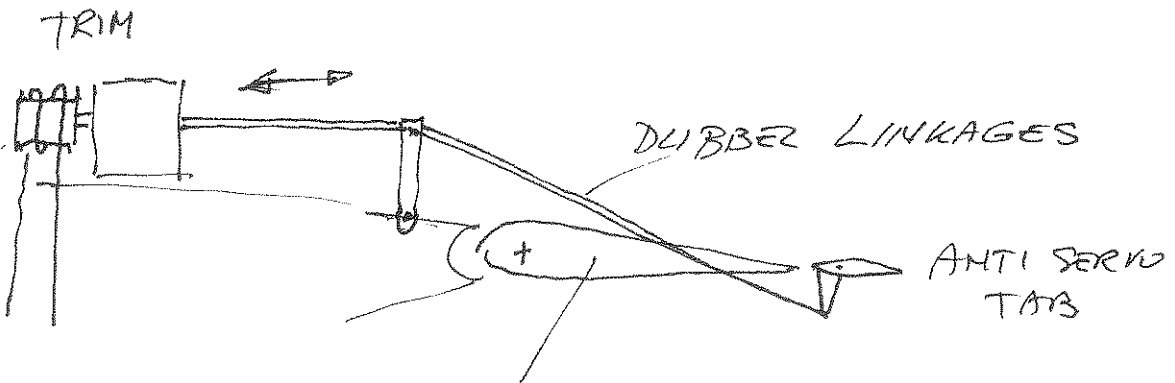
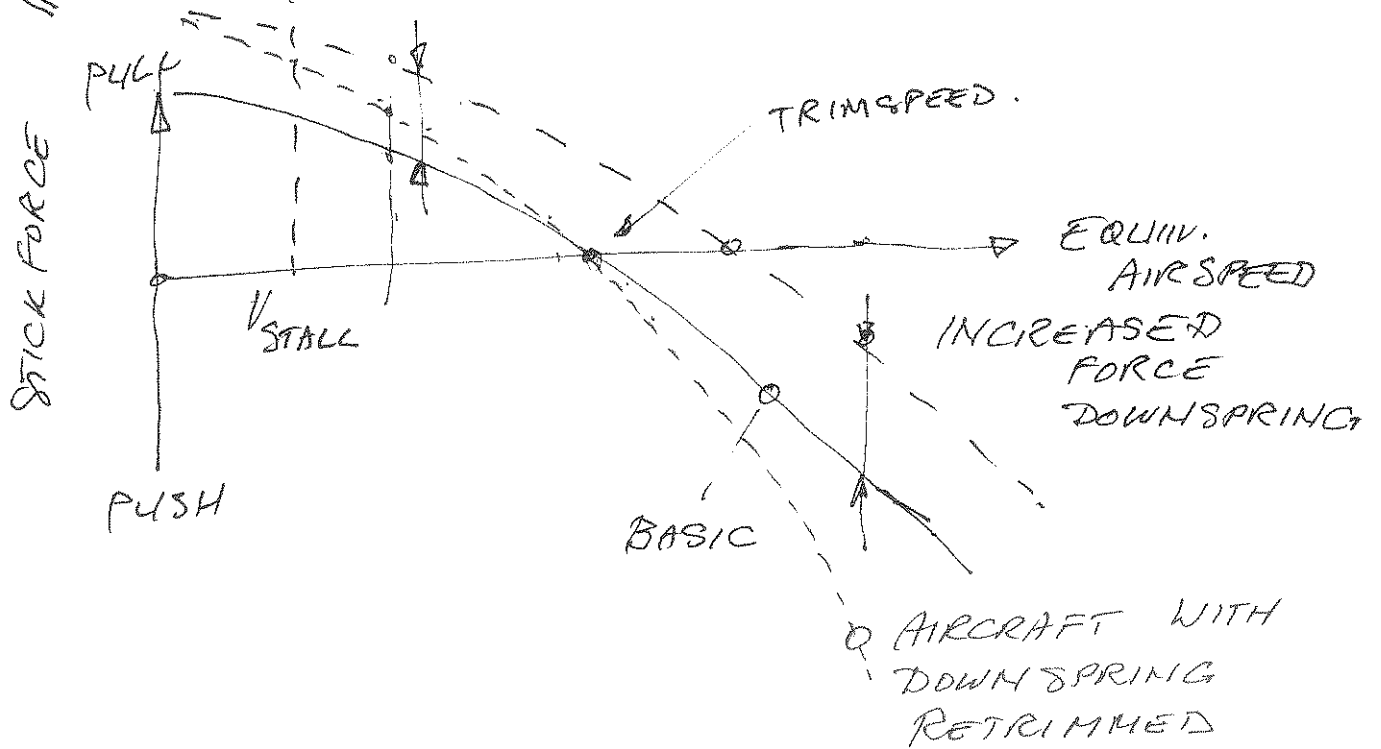
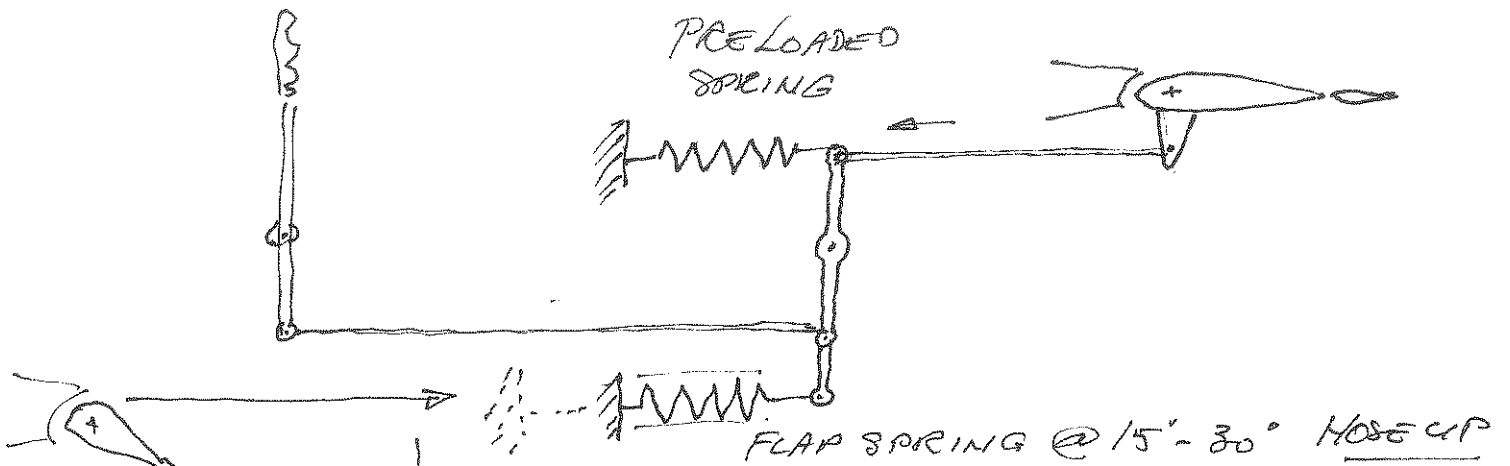

ELEVATOR "HORN TYPE"
(AERODYN. BALANCE)

AILERONS: SPRINGS + FIXED TAB

I. Trim tab activation

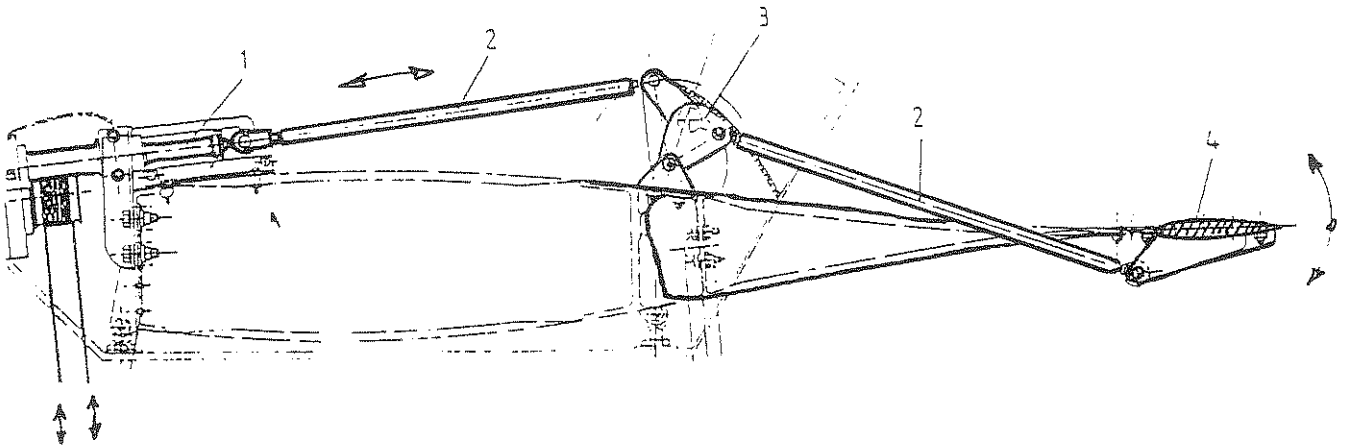

1 = trim tab drive
2 = trim control rods

3 = torsion shaft
4 = trim tab

Fig.: 1
Trim tab activation

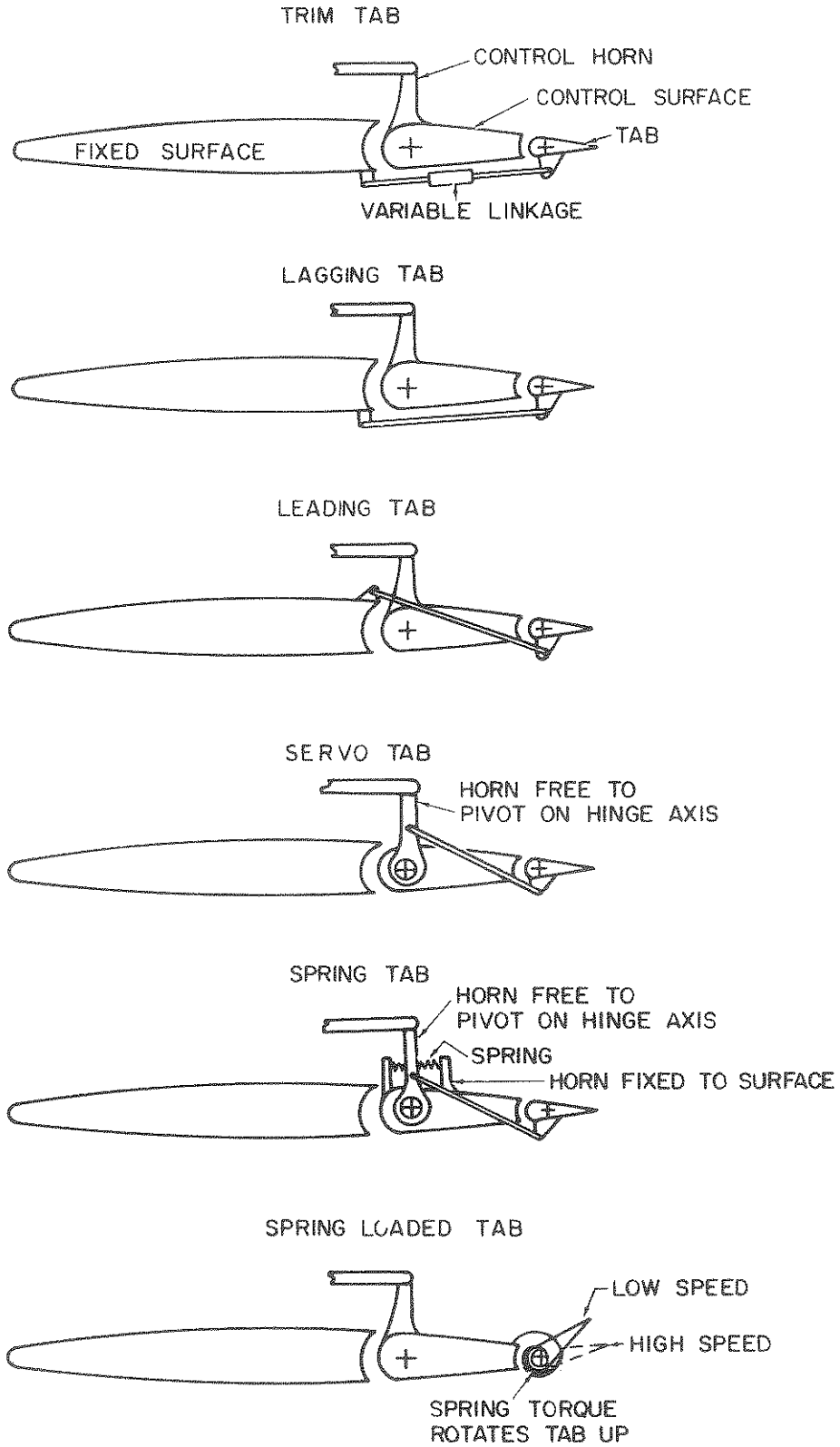
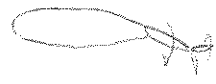

Figure 4.18. Various Tab Devices

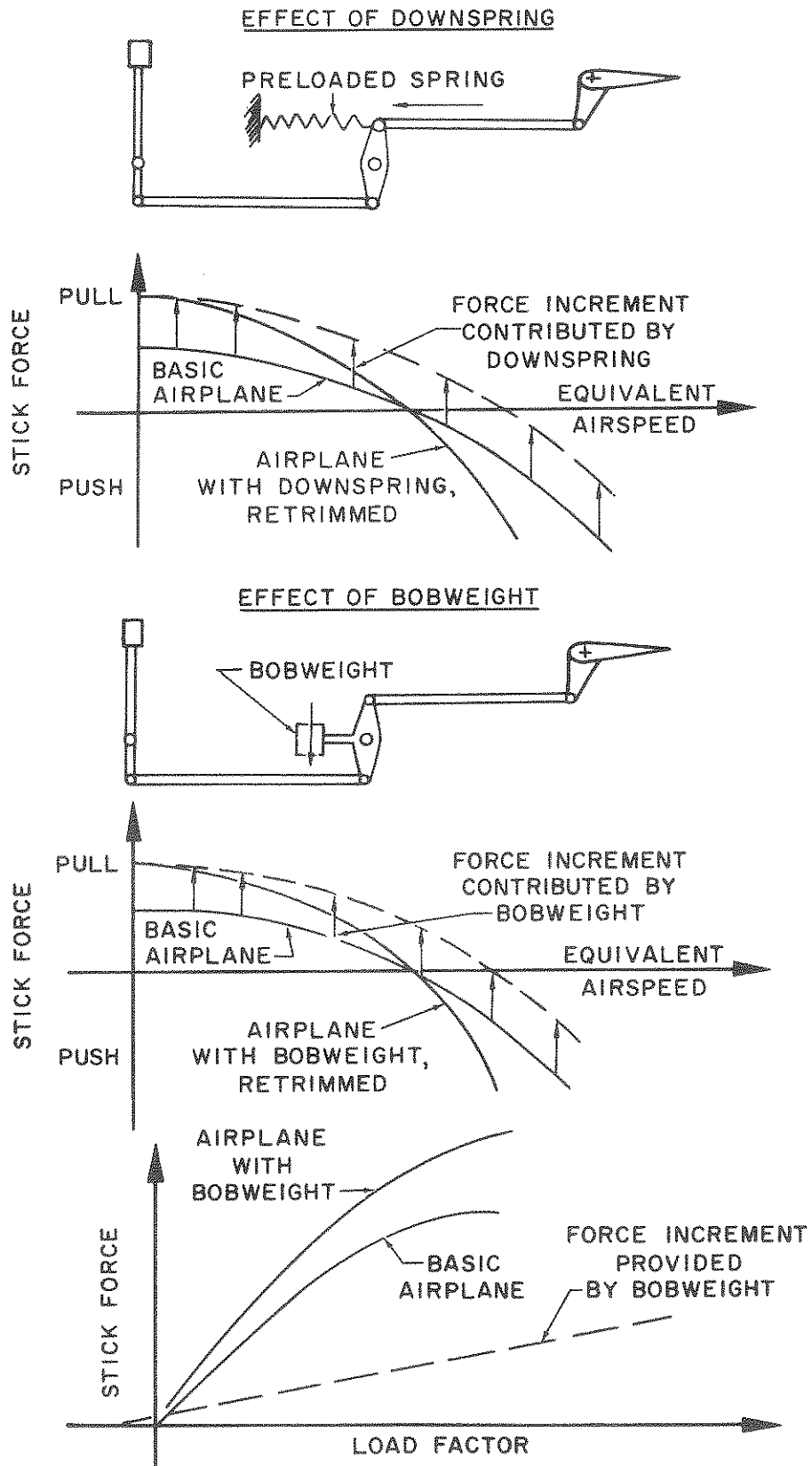
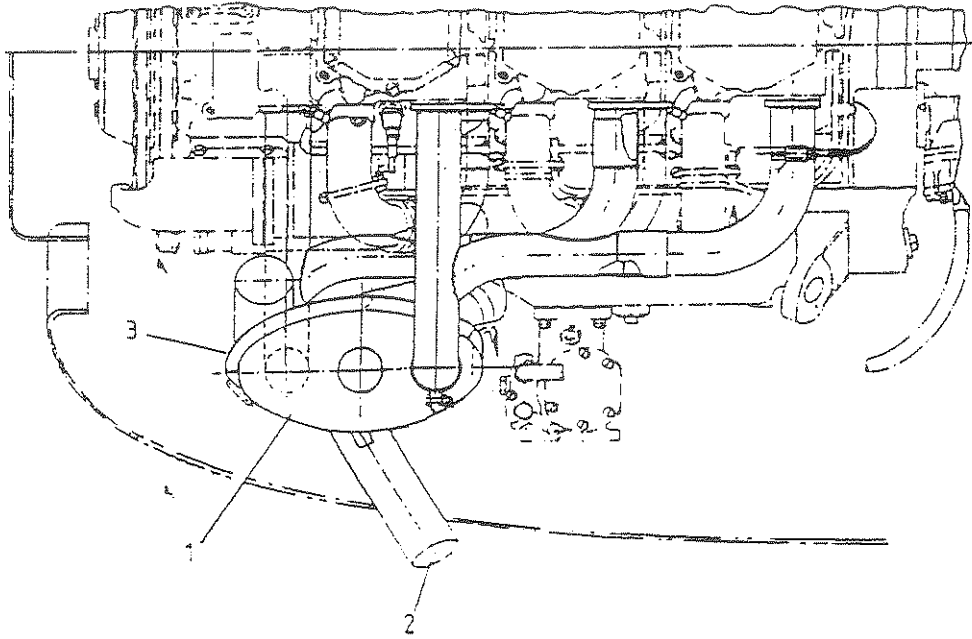

Figure 4.17. Tailoring Control Forces



1 = muffler

2 = tail pipe

3 = heat exchanger

Fig.: 1 Exhaust system

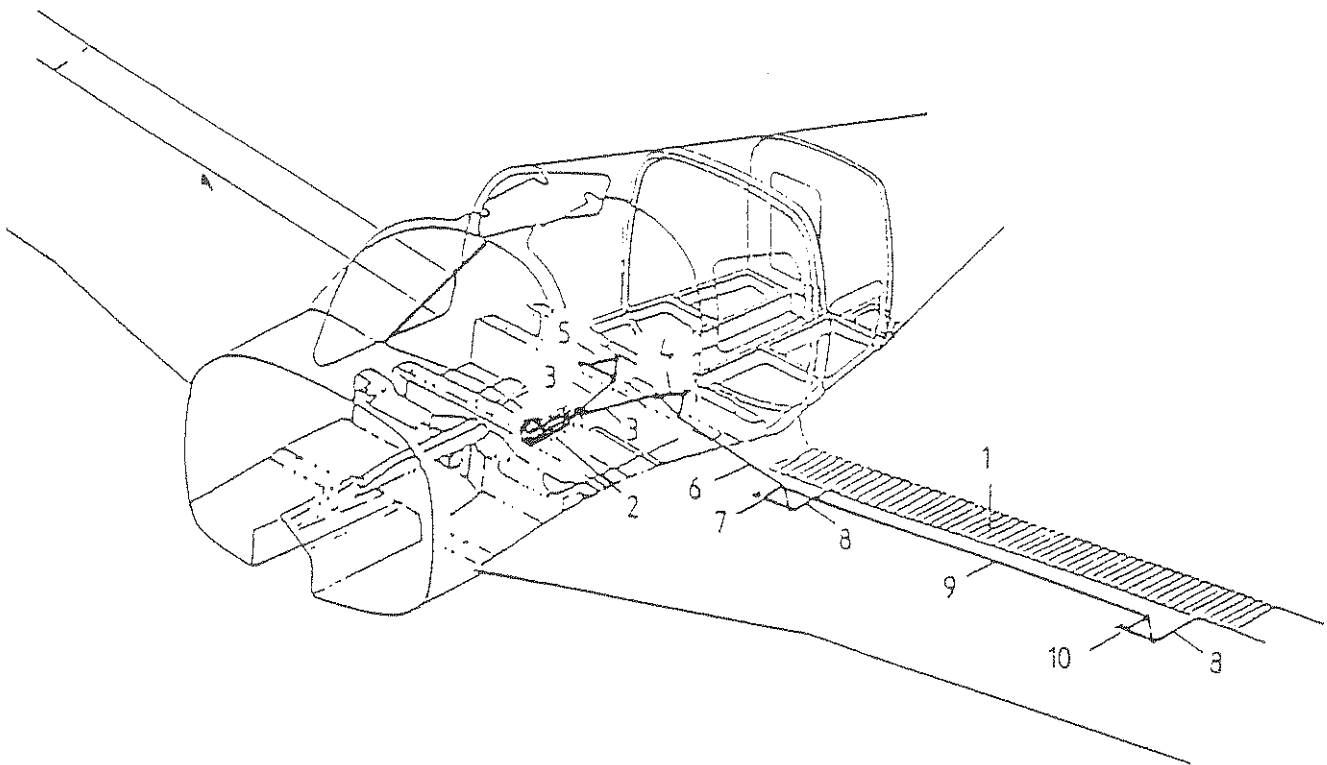

Fig.: 1

Mechanical flap control

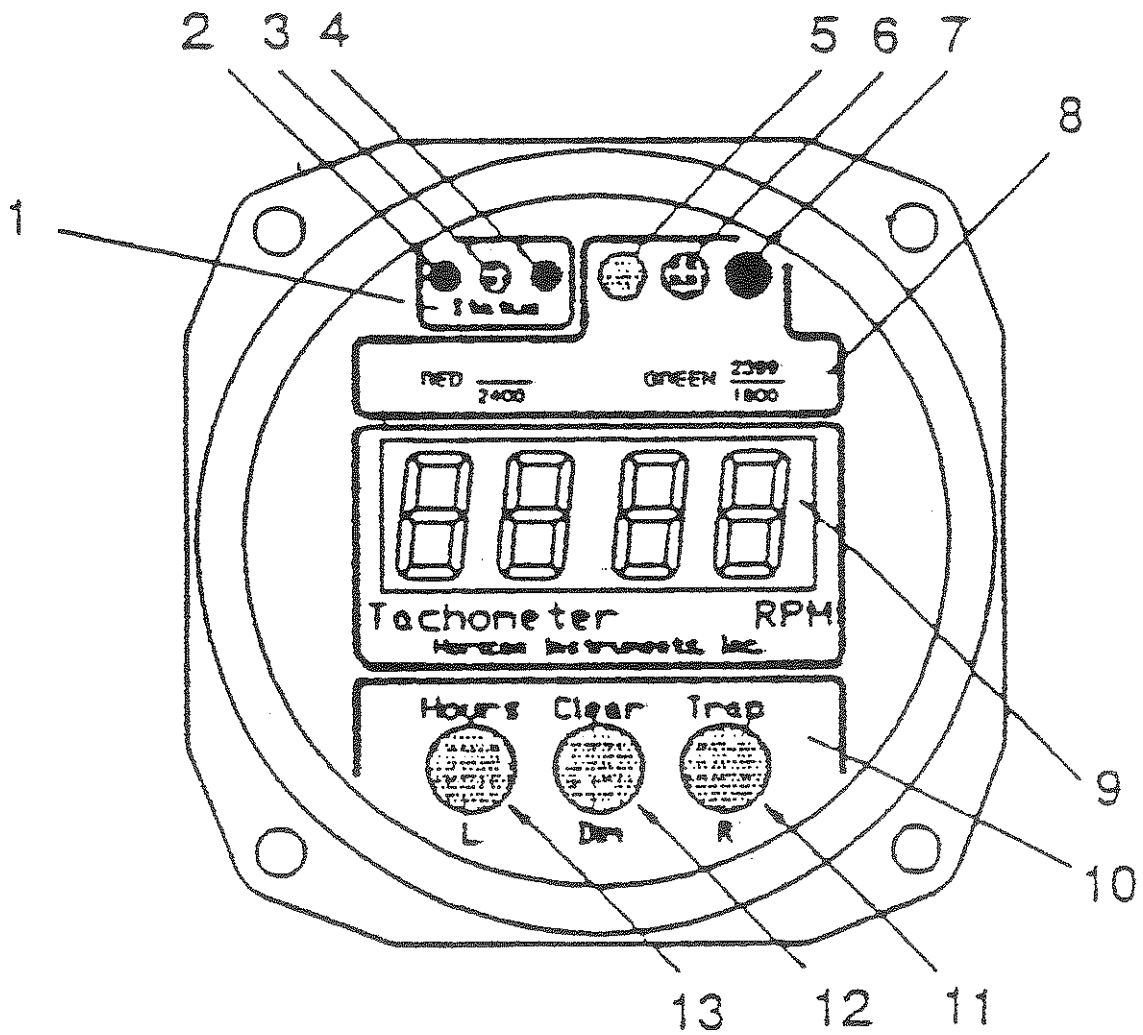

Figure 1: Tachometer P-1000

2224,33

BEFORE FLIGHT: No Fuel Added: No action required if previous value is still stored.

When M.U.F. is applicable:

Right Switch Left & Hold
Right Display: 236
Press Enter

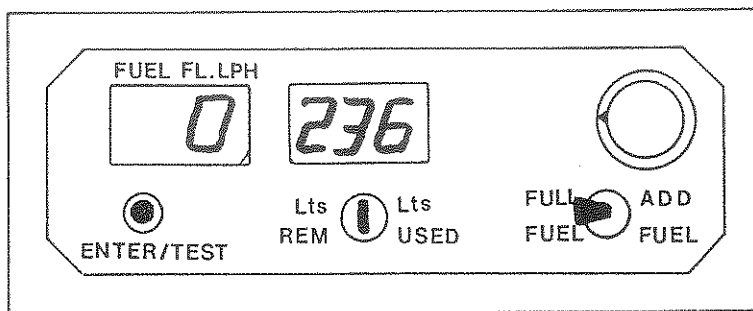

Actions:

Push Left Switch Left
Right Display: 236

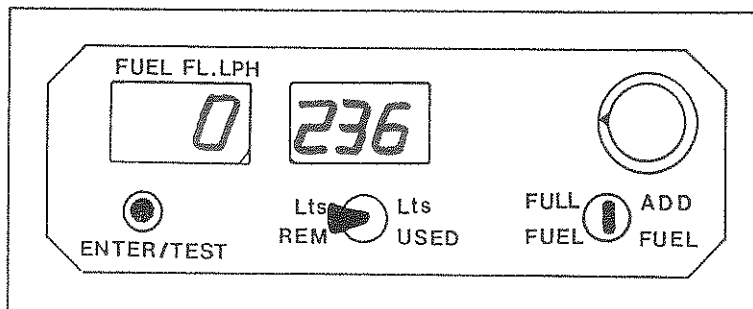

When before flight PARTIAL FUEL ADDED (100 Litres f.i.)

Push Right Switch Right.
Left Switch Left & HOLD

When correct value is displayed:

Press Enter

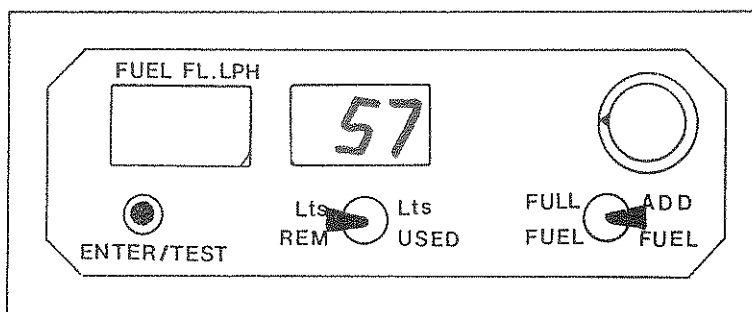

Push Left Switch Left
Display: Actual Fuel
in tanks.

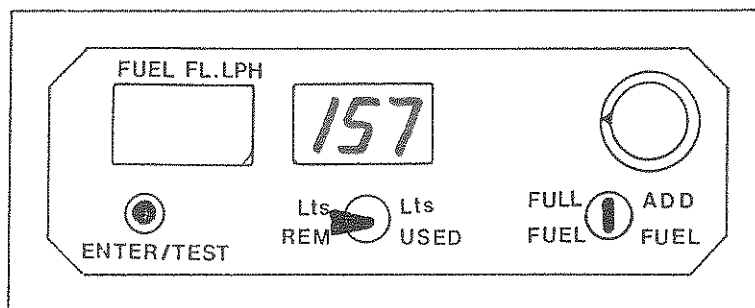

Correction of Input Values:

Left Switch Left : Increase
Left Switch Right: Decrease

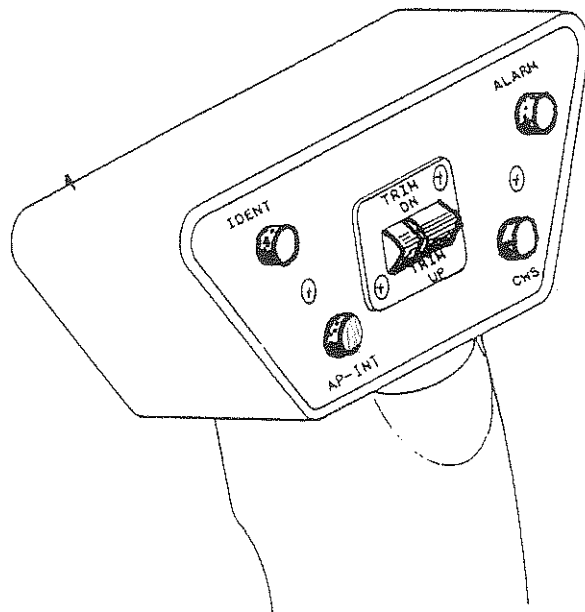

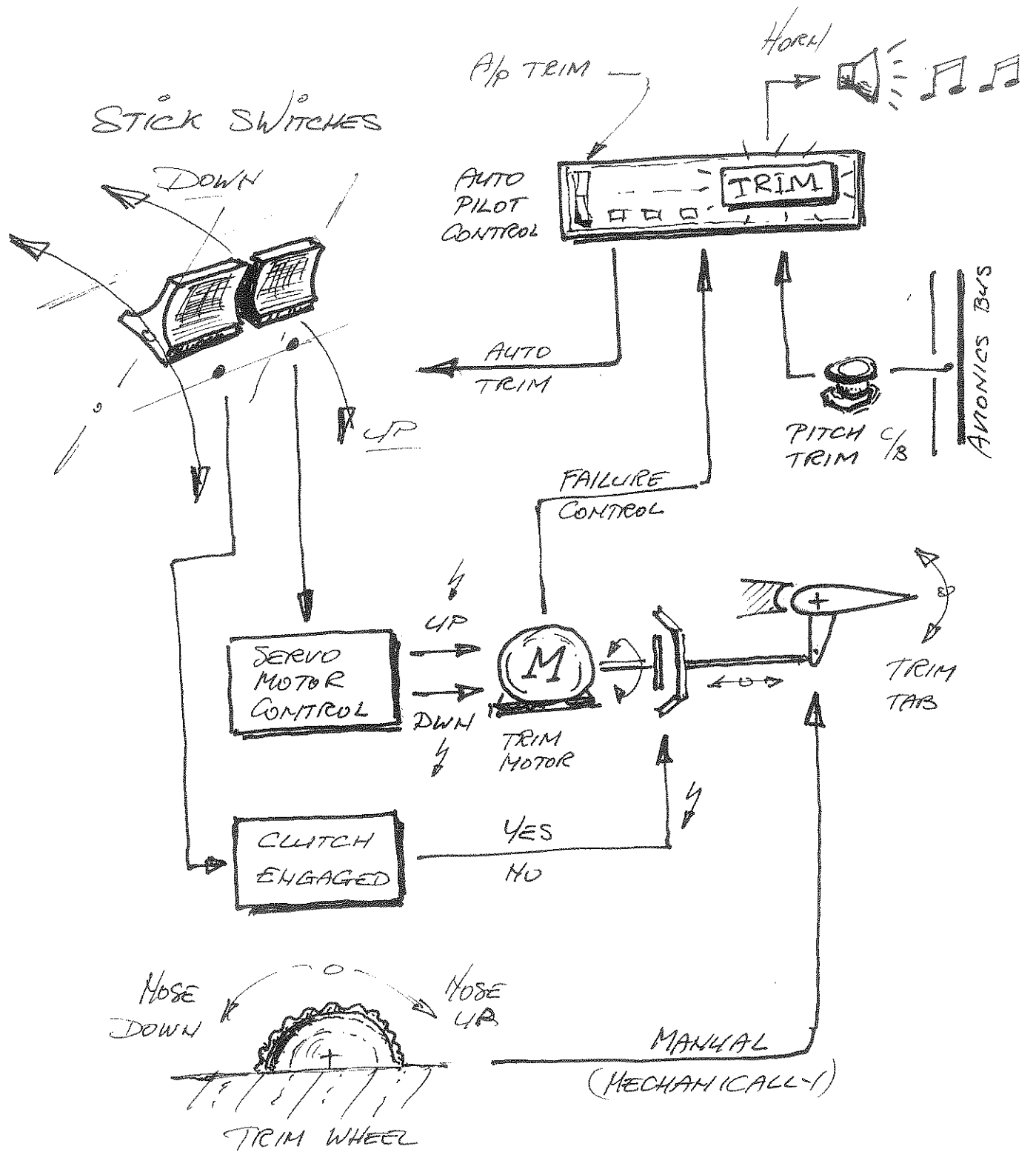

MANUAL (ELECTRIC) ELEVATOR TRIM
 STICK SWITCHES - AUTO PILOT CONTROL
 MANUAL (MECHANIC) ELEVATOR TRIM
 CONTROL & WARNING

BASIC SCHEMATIC

RUSCHMEYER
 JAN 1995 v.1.0.



FUEL

PRINCIPE SCHEMA
FUEL INJECTION (BENDIX RS.A)
PIPER ARROW II

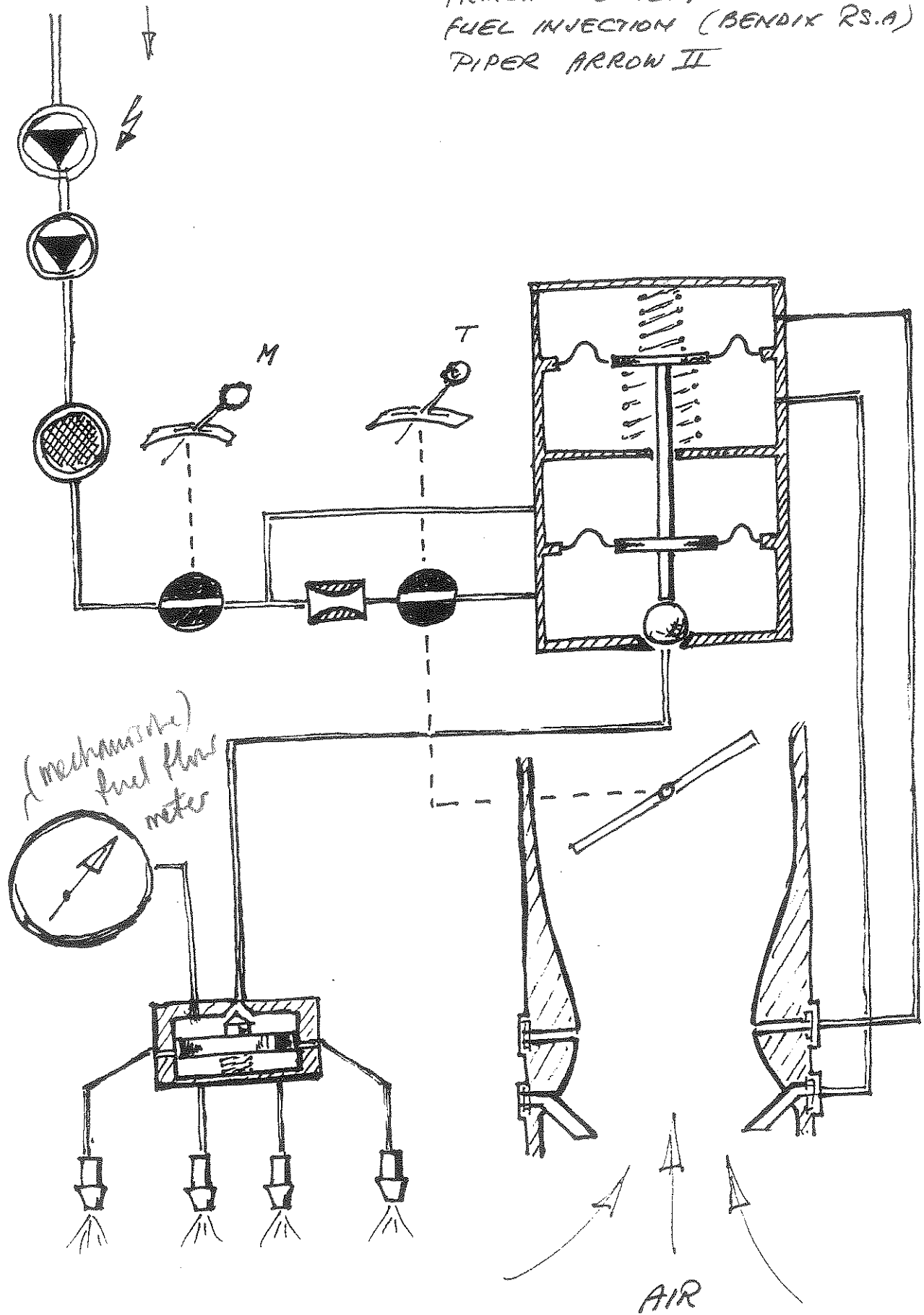

L/L 3/588

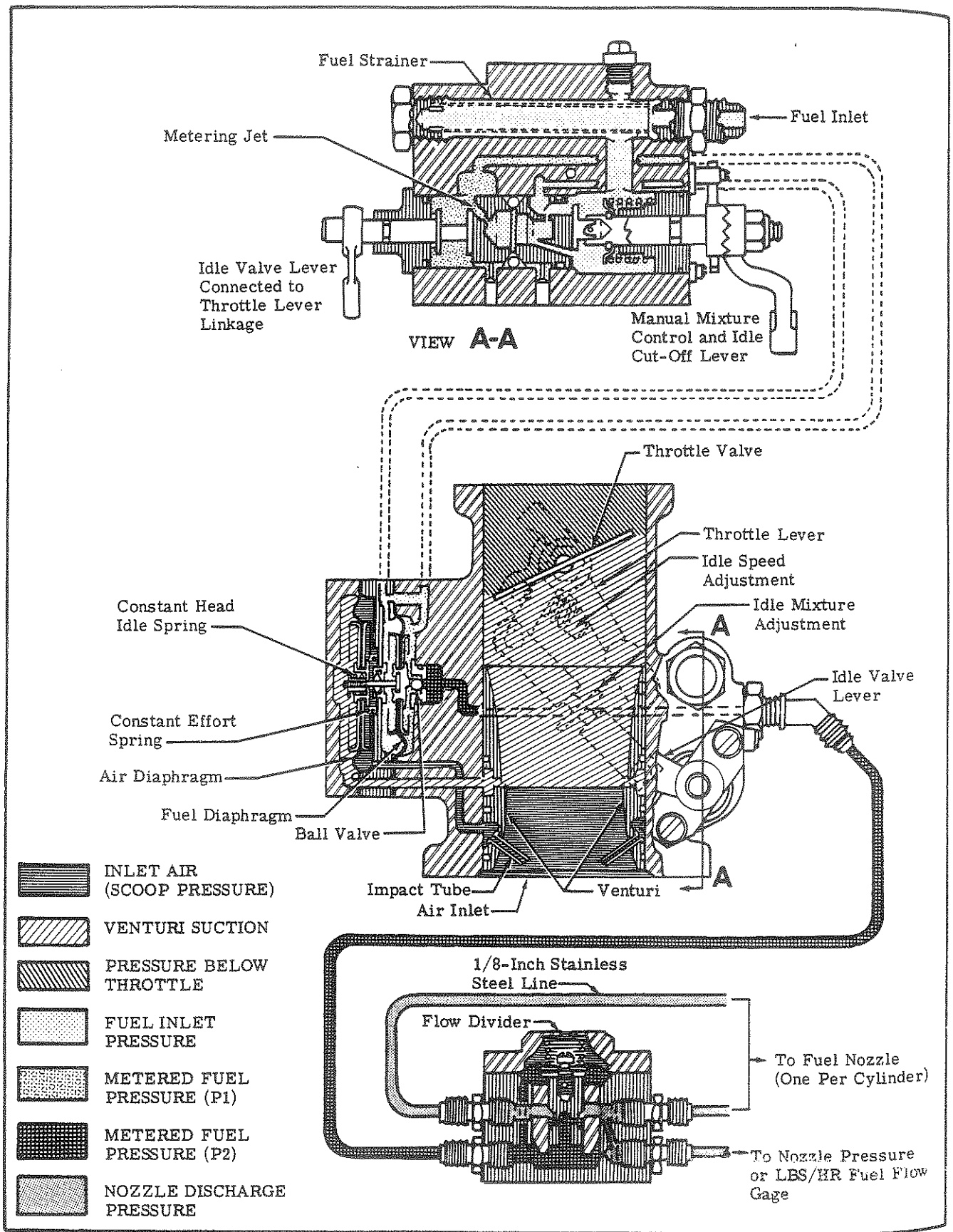

Fuel Injection System Schematic

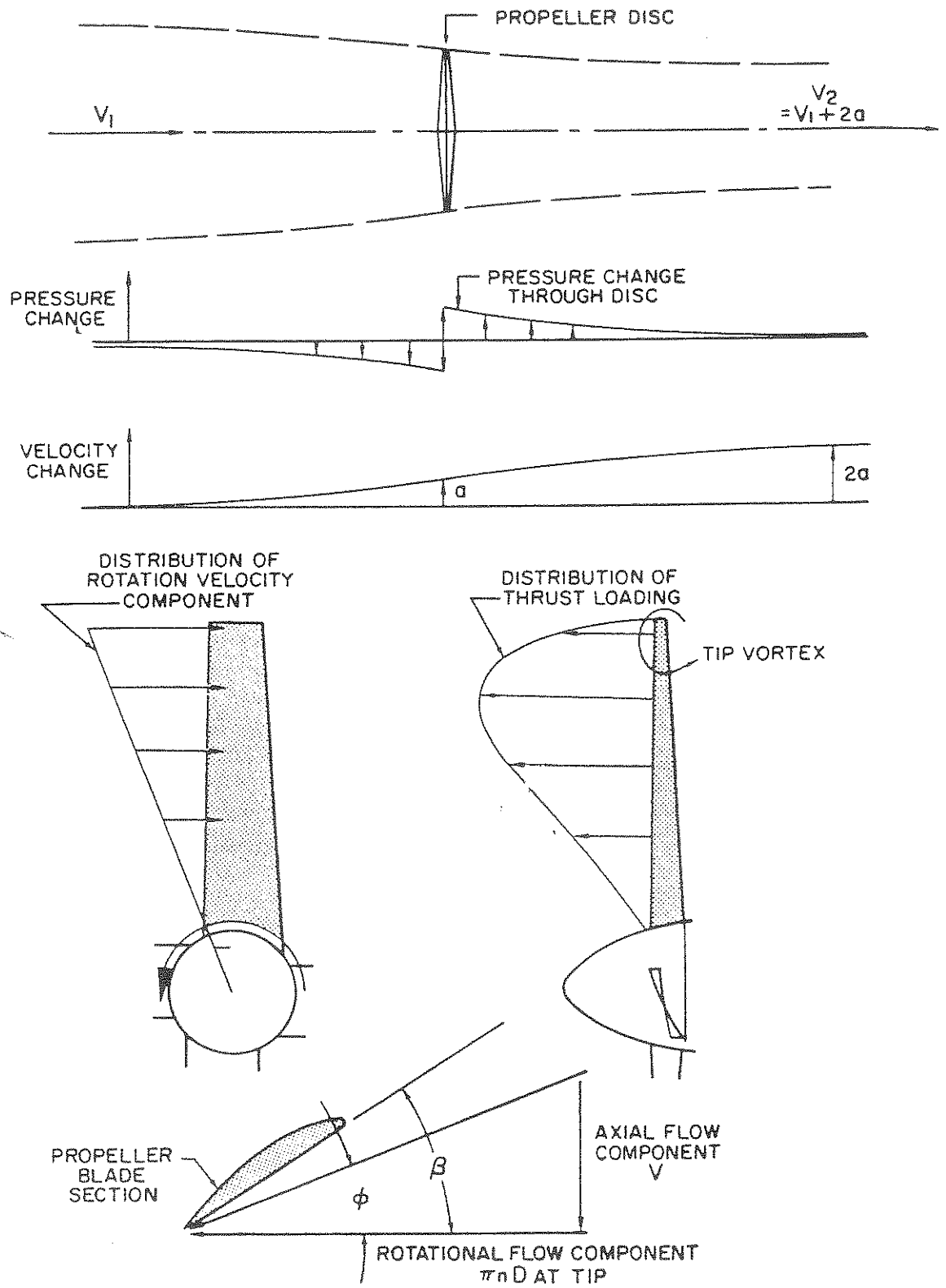

Figure 2.18. Principles of Propellers

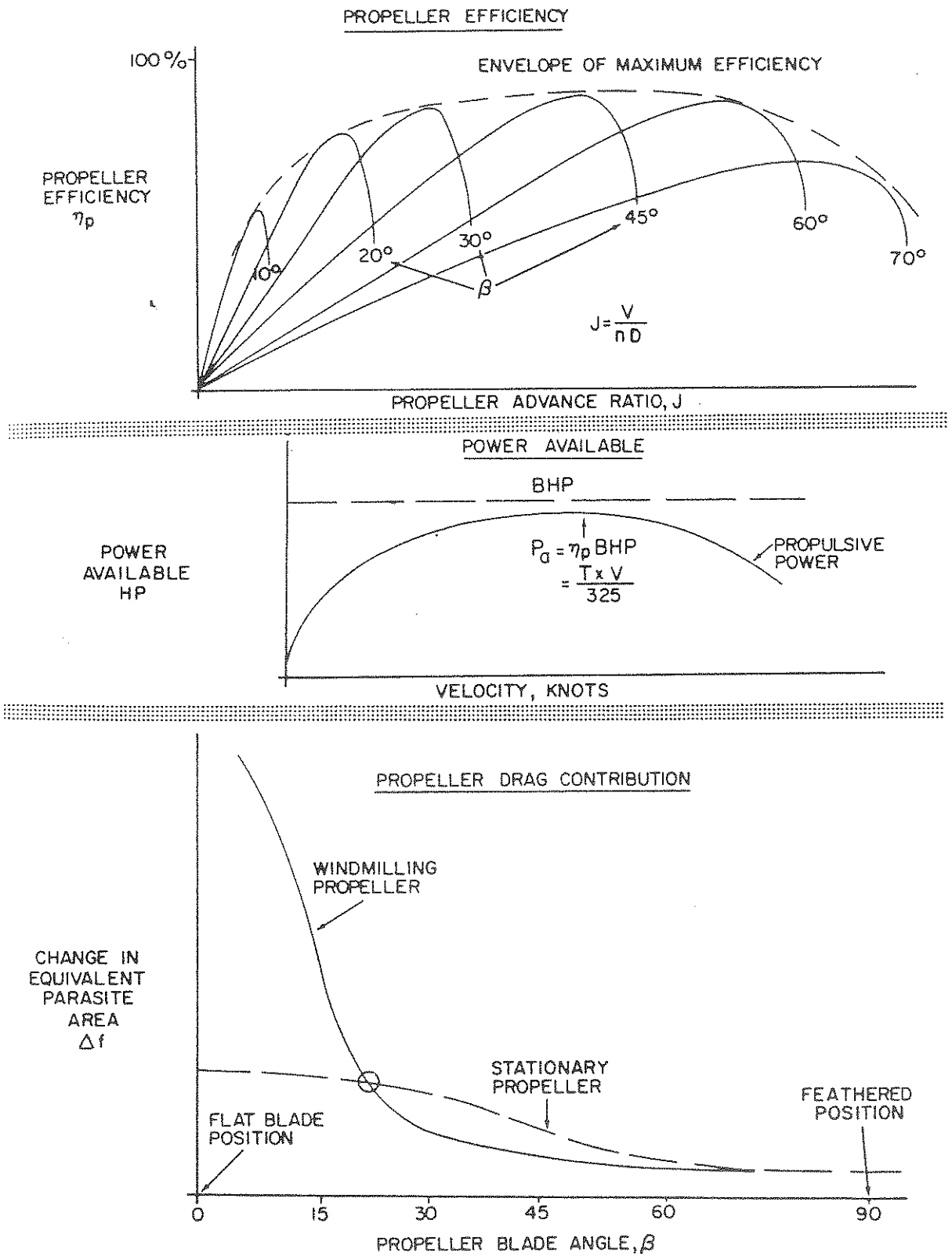
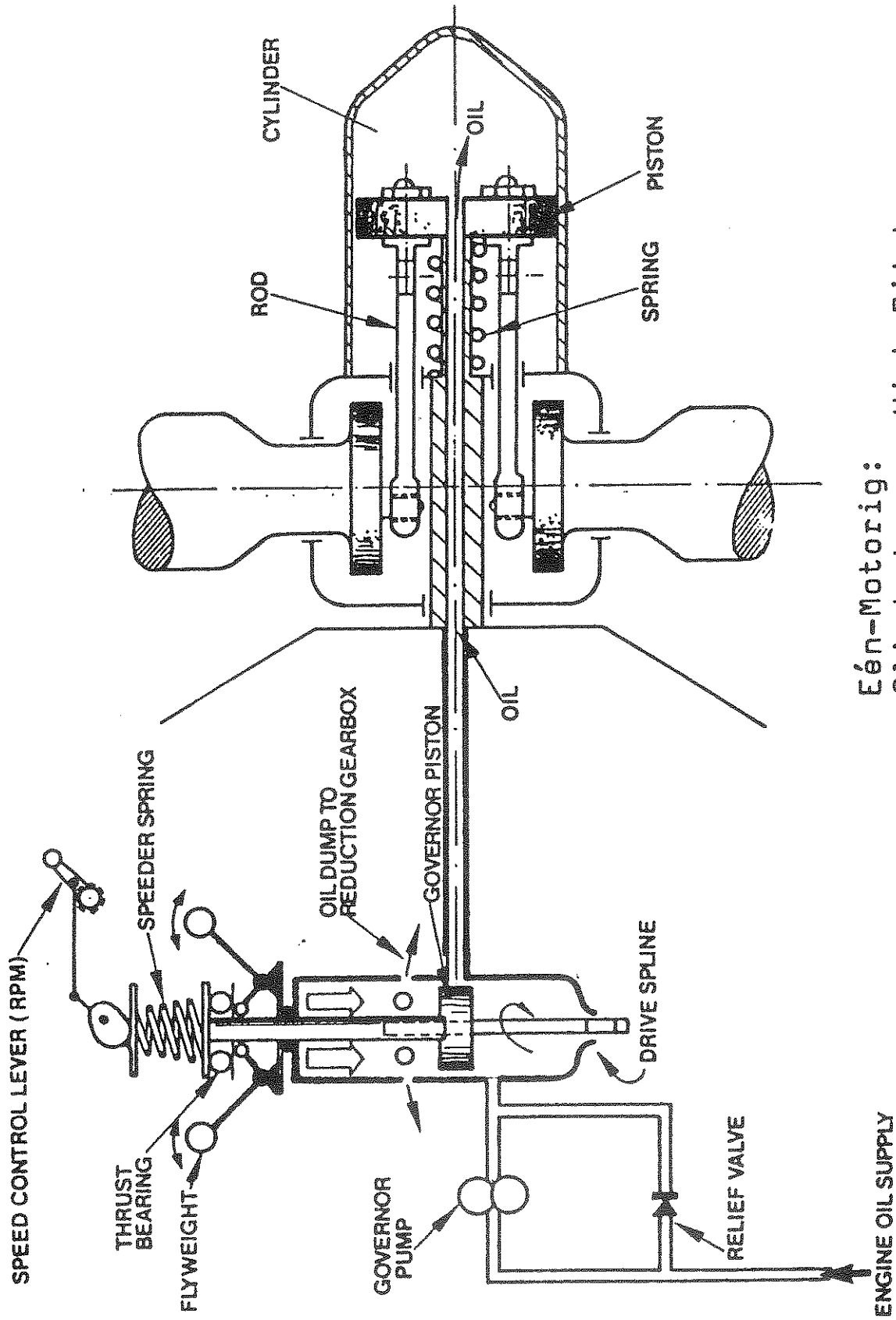

Figure 2.19. Propeller Operation



Eén-Motorig: → High Pitch
Oliedruk → Low Pitch
Veer + Centrifugaalkracht →



SPEED CONTROL LEVER (RPM)

OVERSPEED CONDITIE

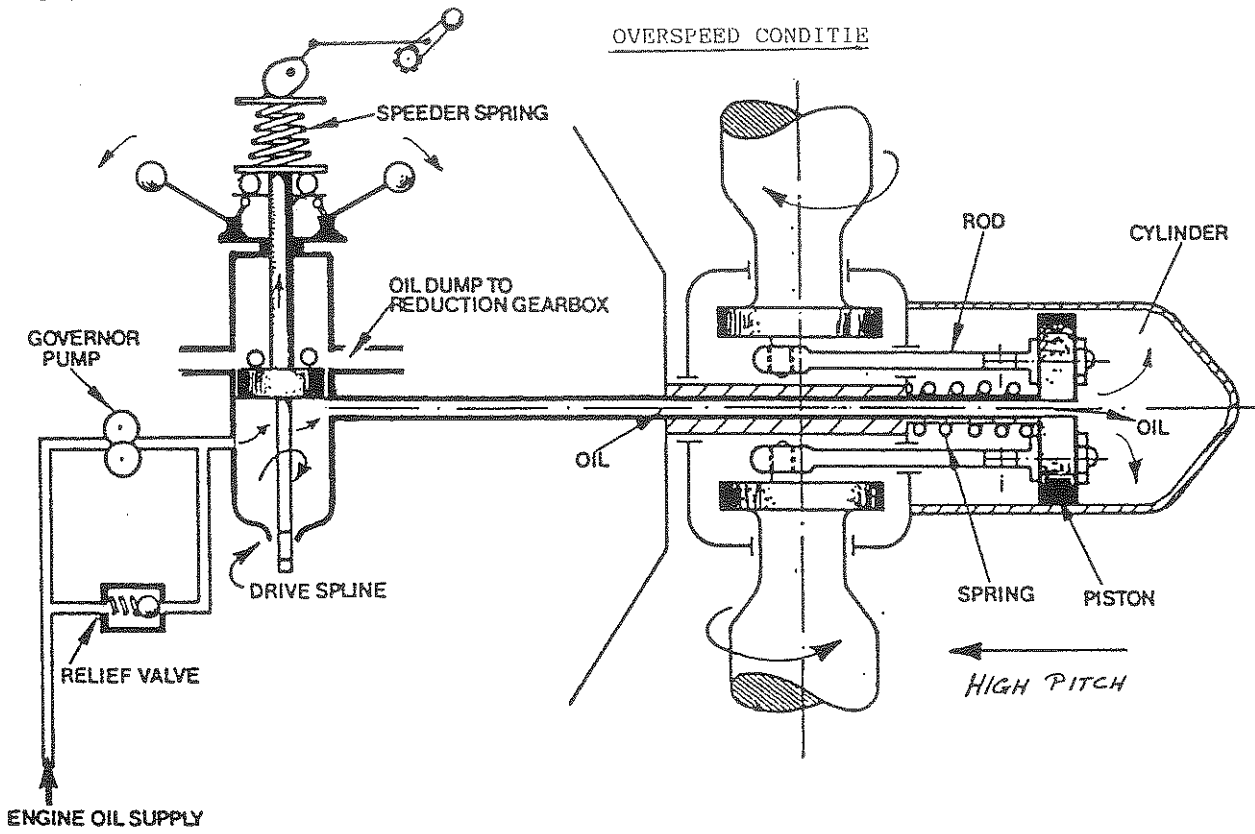

SPEED CONTROL LEVER (RPM)

UNDERSPEED CONDITIE

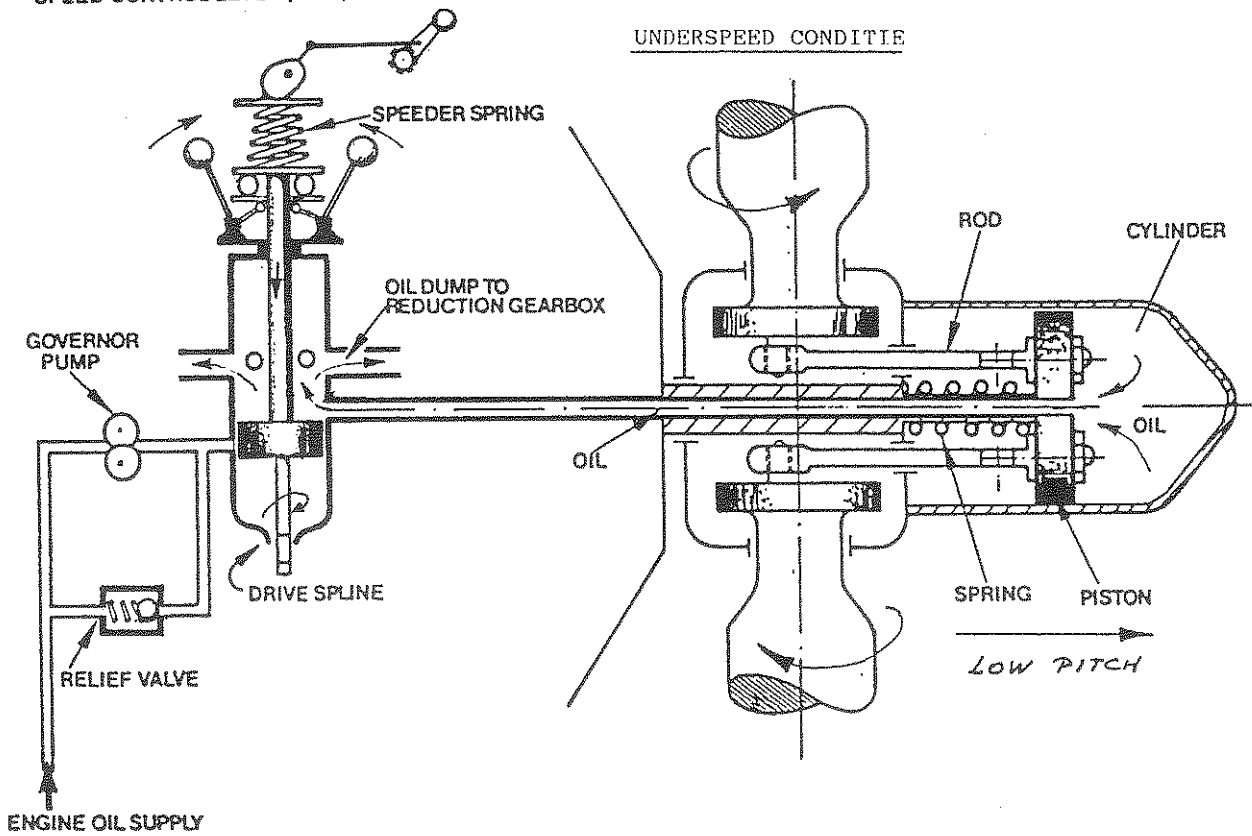

I. Battery, starter and ignition

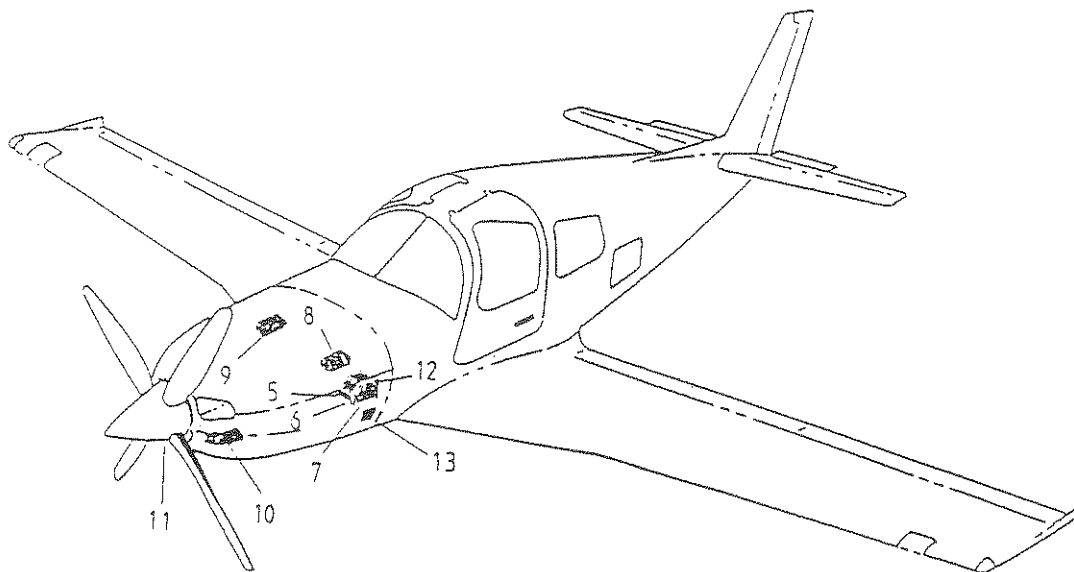
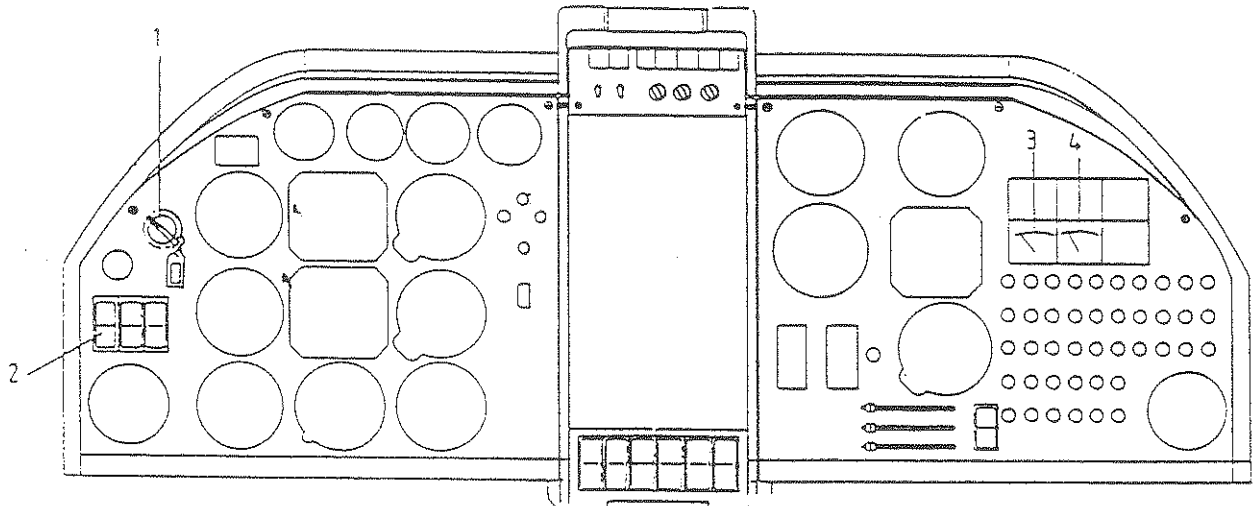

- | | | |
|----------------------------|--------------------------|----------------------------|
| 1 = ignition switch | 6 = starter relay | 11 = alternator |
| 2 = battery, master switch | 7 = external power relay | 12 = battery |
| 3 = voltmeter | 8 = magneto, left | 13 = external power supply |
| 4 = amperemeter | 9 = magneto, right | |
| 5 = battery relay | 10 = starter | |

ELECTRIC SYSTEM

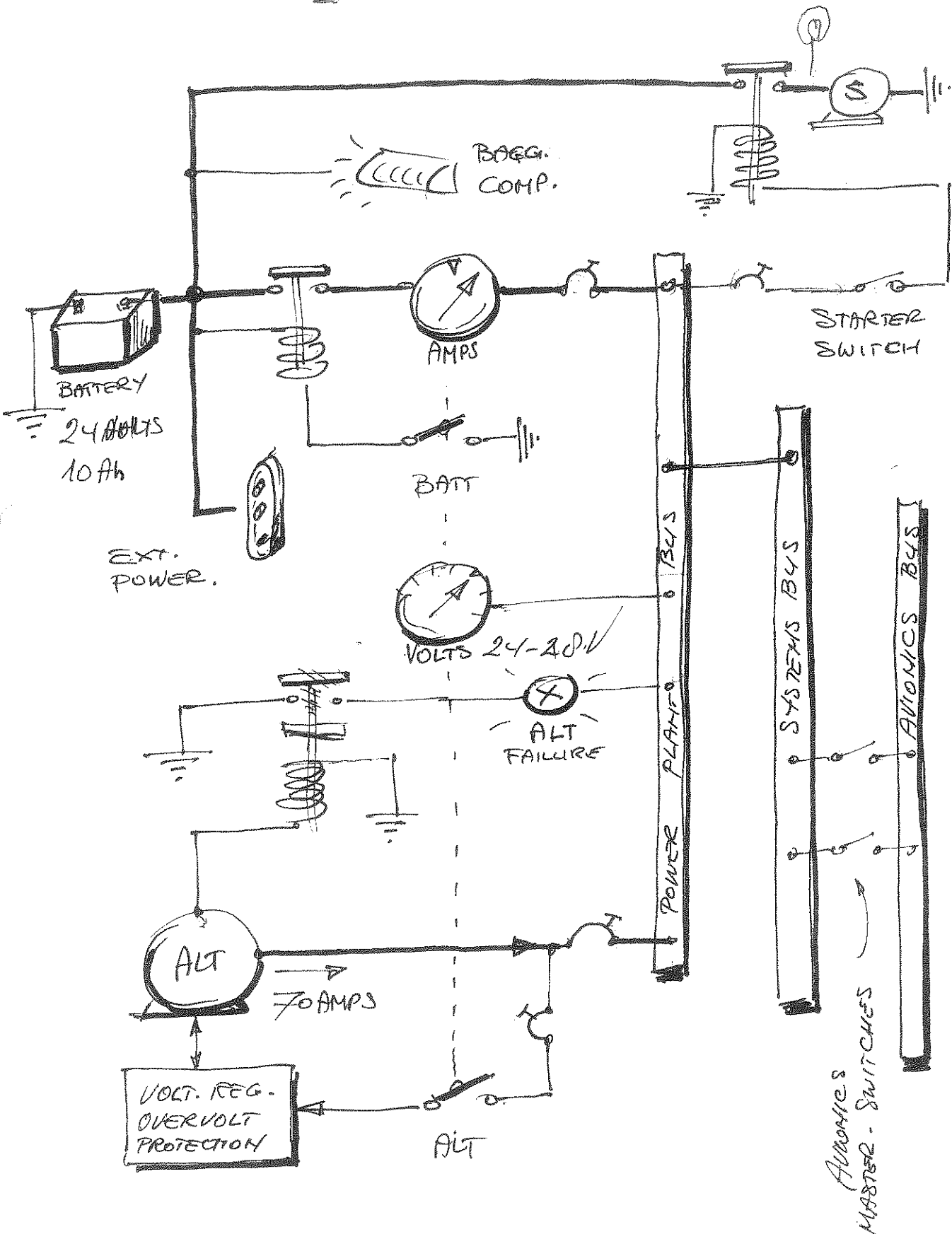

BASIC ELECTRICAL SYSTEM
LOAD DISTRIBUTION

RUSCHMEYER
JANUARI 1995 v. 1

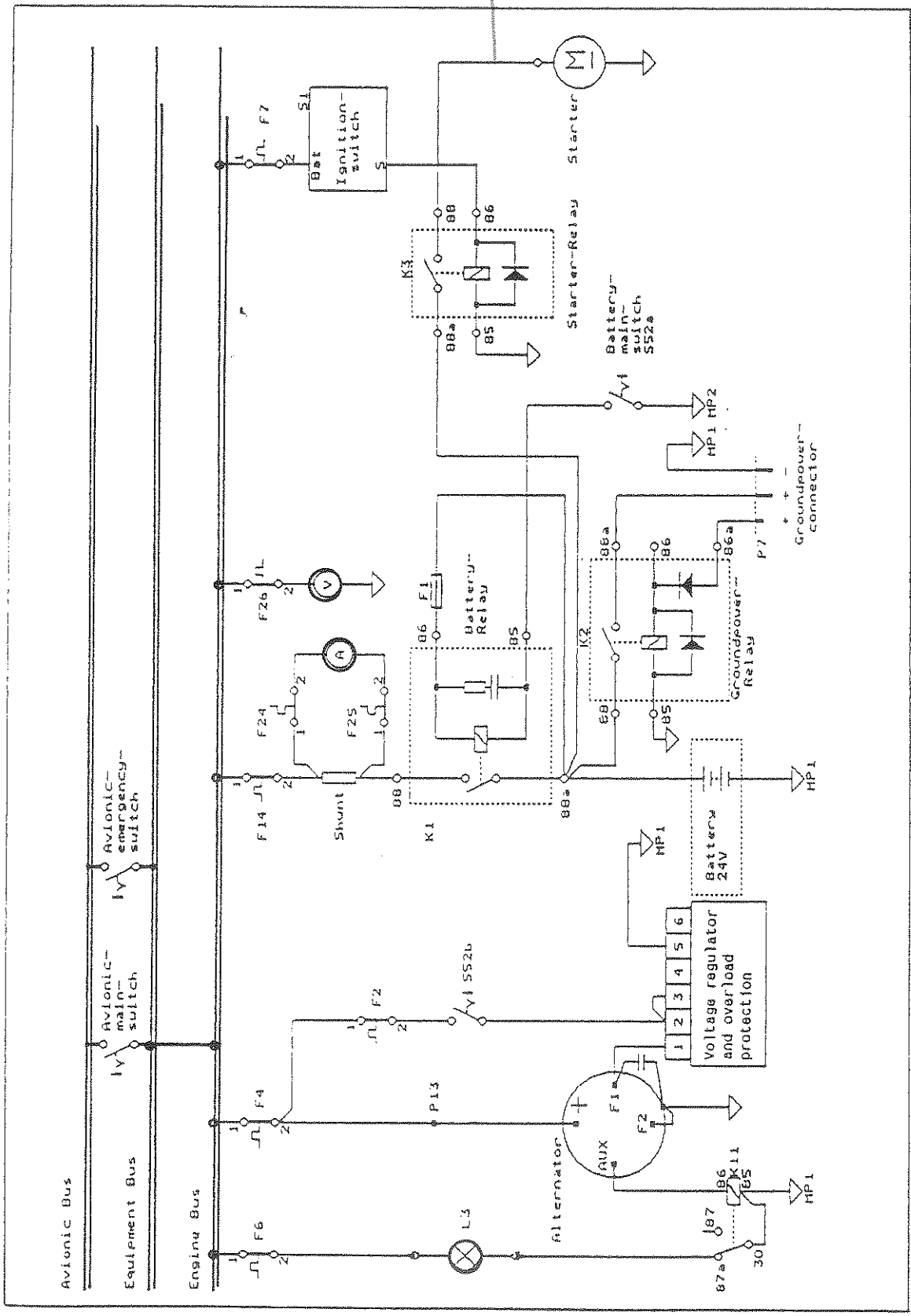

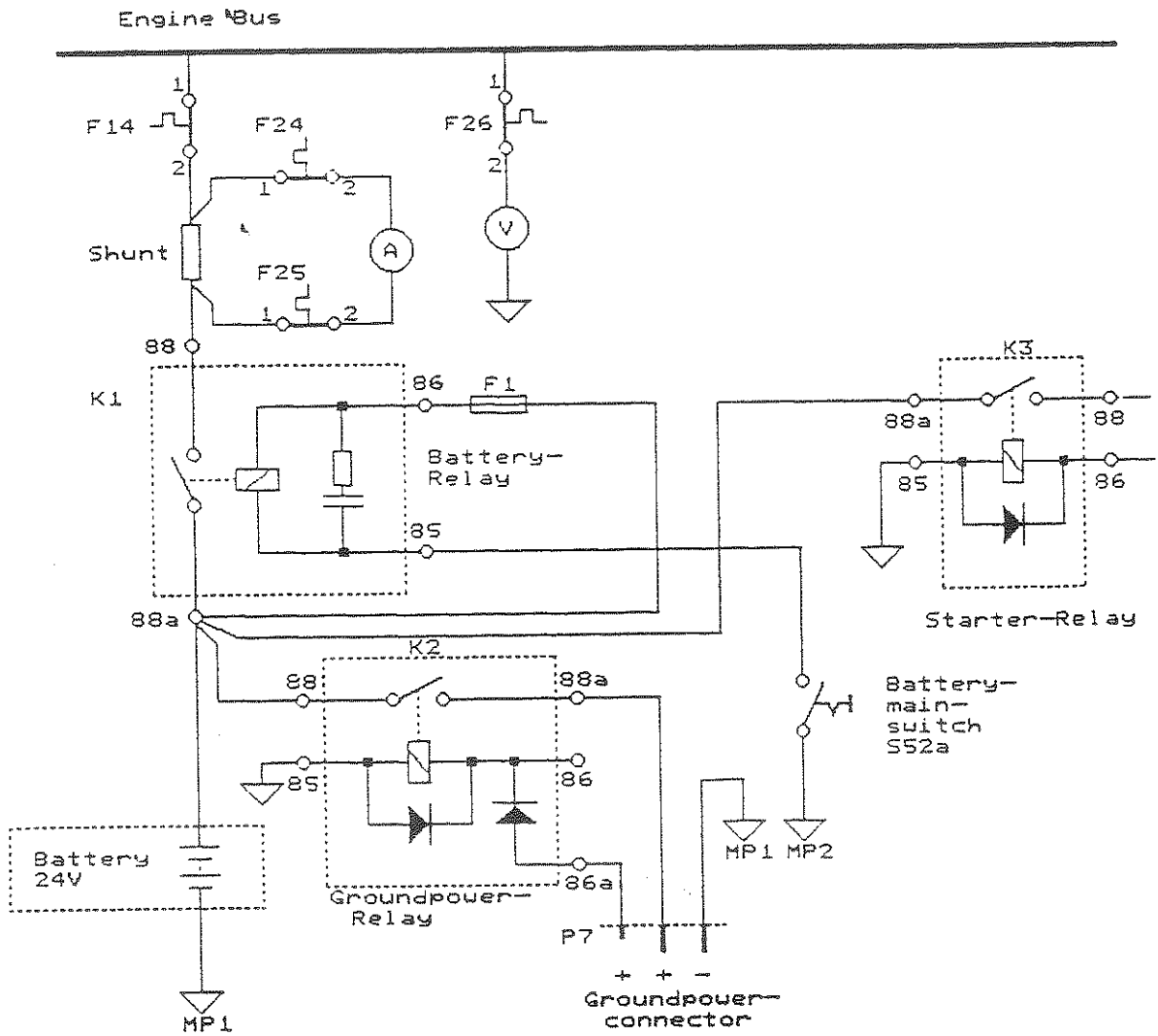
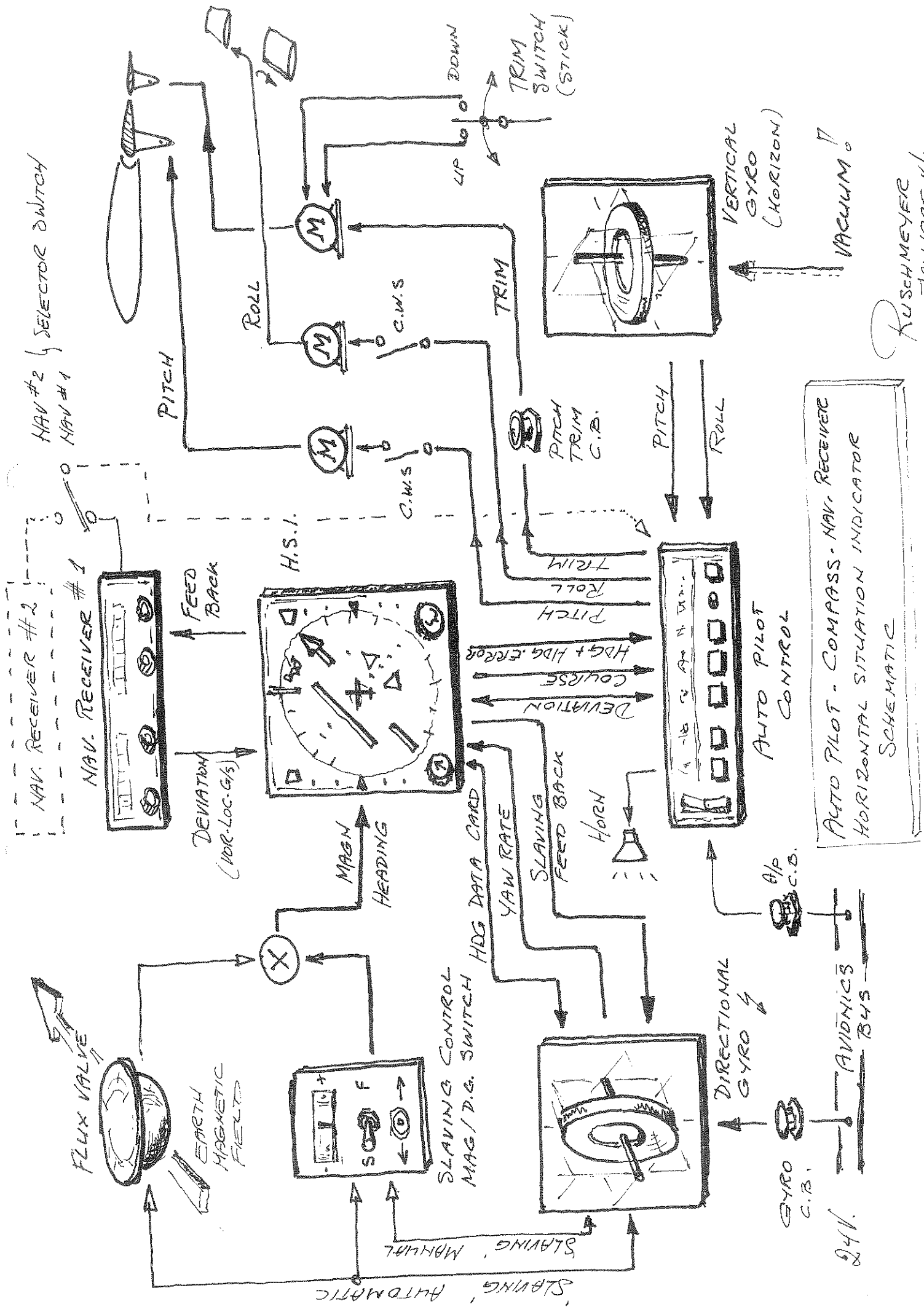
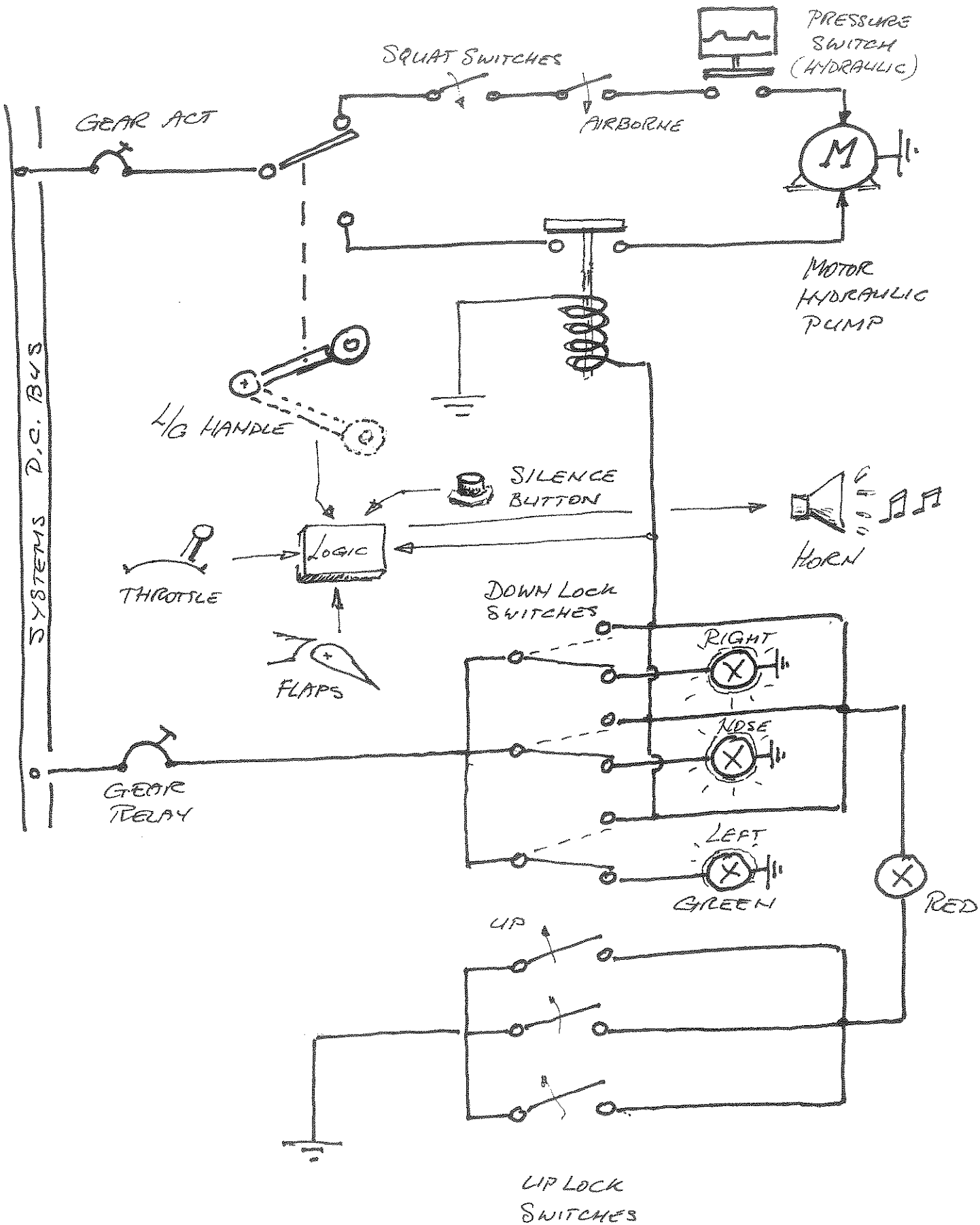

Fig.: 1
External power supply terminal



RUSCHMEYER
JAN 1945 U.S.



LANDING GEAR OPERATION
 &
 INDICATION SCHEMATIC

RUSCHMEIER
 JAN 1995 V.L.

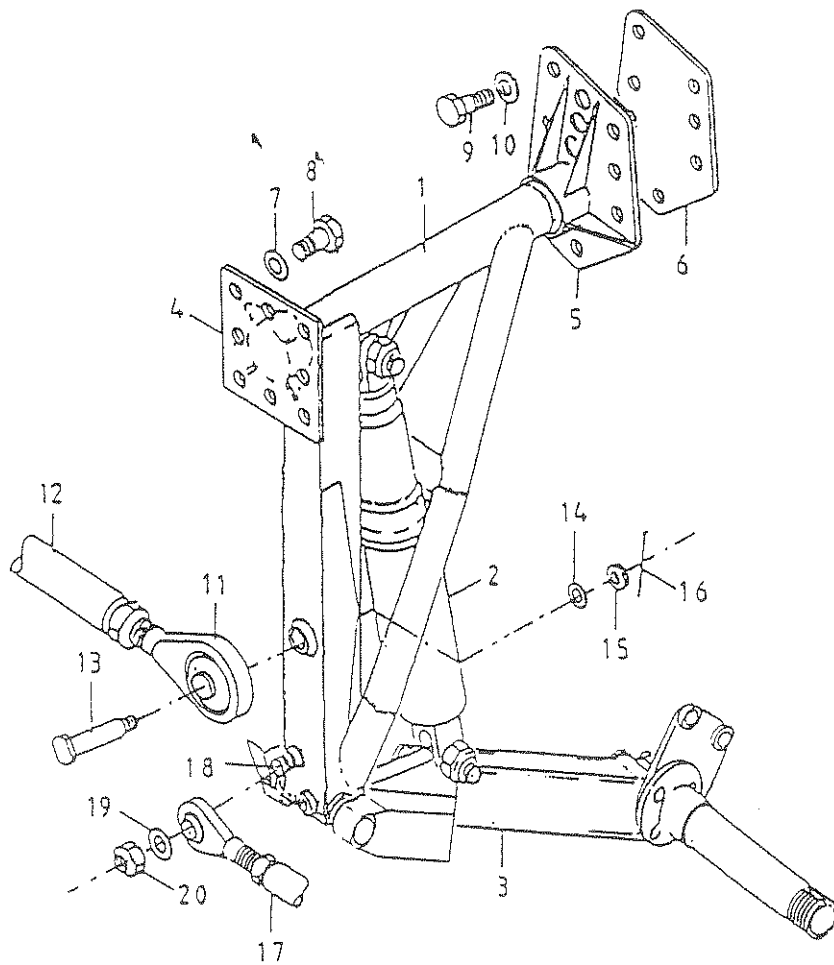

- 1 = landing gear strut
- 2 = shock absorber
- 3 = lever arm
- 4 = landing gear bearing
- 5 = landing gear bearing
- 6 = shim plate
- 7 = washer
- 8 = screw
- 9 = screw
- 10 = washer
- 11 = ball-and-socket bearing
- 12 = radius strut
- 13 = bolt
- 14 = washer
- 15 = nut
- 16 = cotter pin
- 17 = control rod - landing gear door
- 18 = stay bolt
- 19 = washer
- 20 = nut

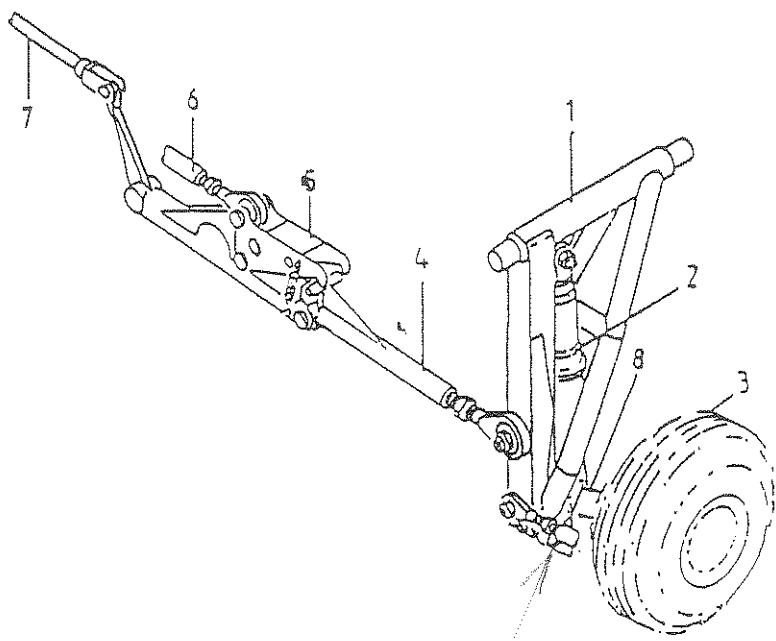

- 1 = landing gear strut
- 2 = shock absorber
- 3 = landing gear wheel
- 4 = radius strut
- 5 = locking mechanism
- 6 = gear operating jack
- 7 = gas-loaded spring
- 8 = lever arm

Squat switch (inhibits gear-up)

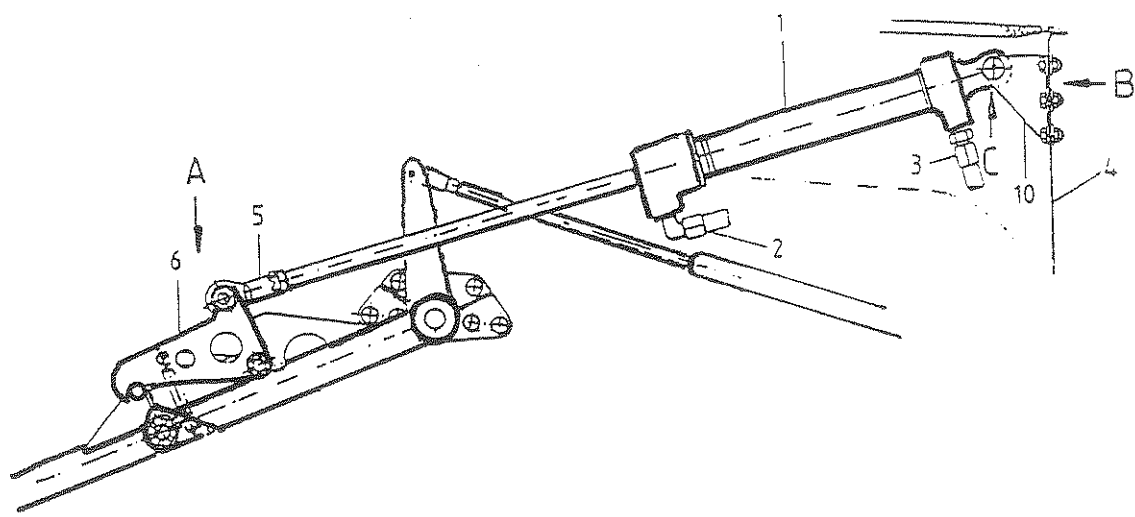

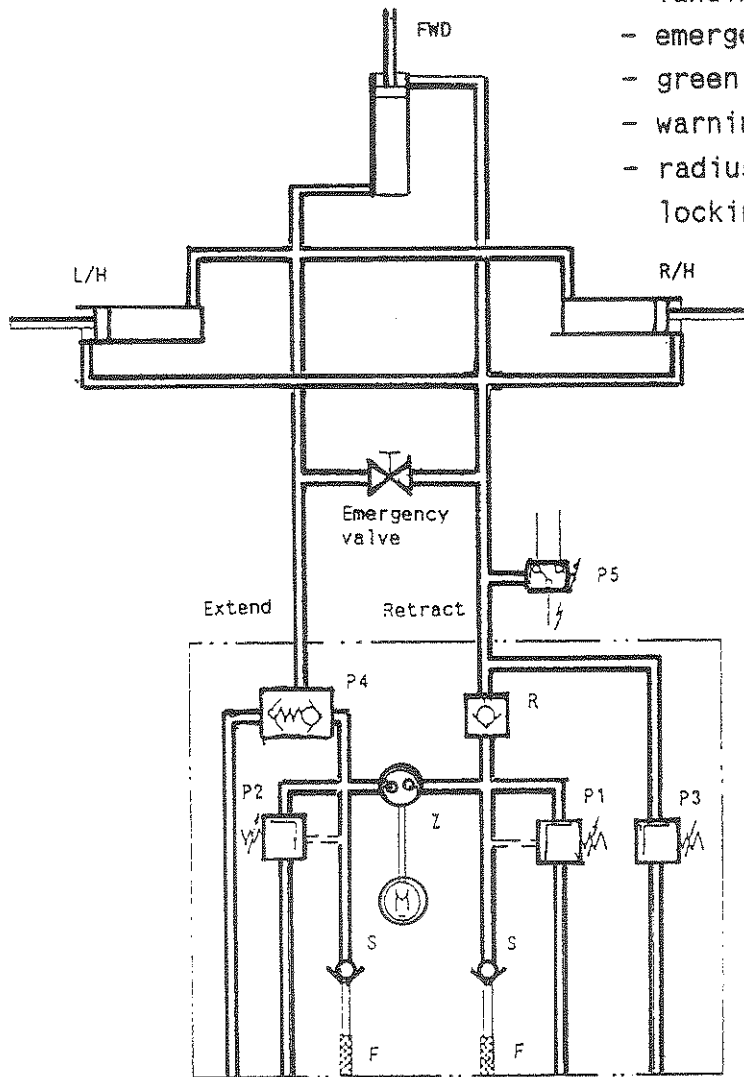

- landing gear switch "DOWN"
- emergency lever "NORMAL"
- green control lamps "ON"
- warning signal "OFF"
- radius struts extended and jack locking devices engaged

Automatic circuit breaker

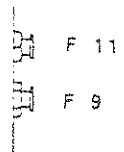

Landing gear switch



Position:
"DOWN"

Emergency lever



Position:
"NORMAL"

Control lamps

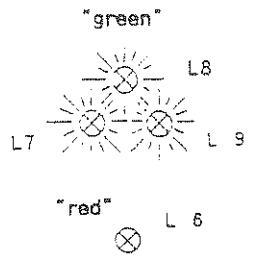

Pump with control unit

Fig.: 02

Landing gear: "DOWN and locked"

FUEL SYSTEM

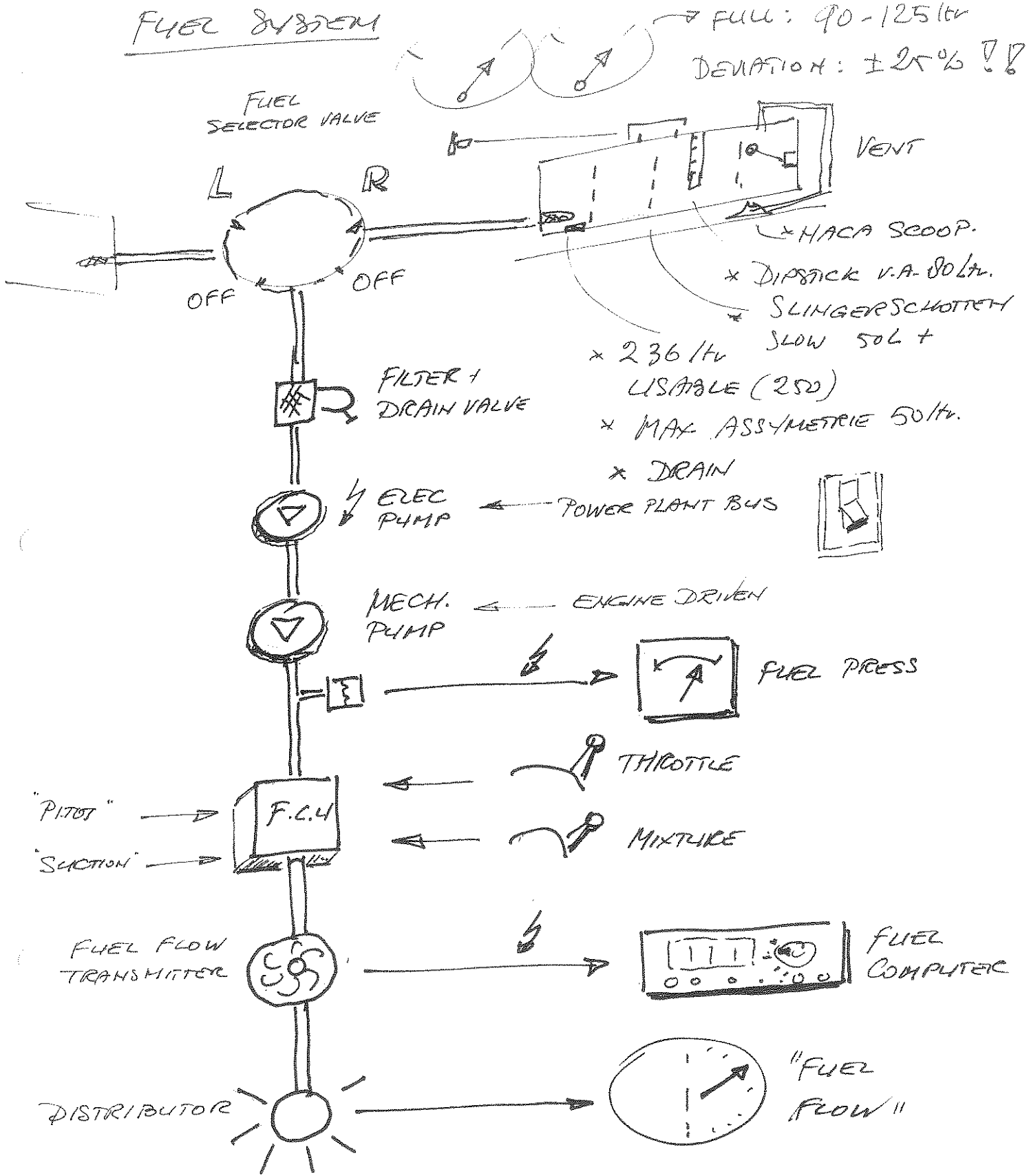

* GROUNDING PLUG.



* TANK.

FUEL SYSTEM
BASIC SCHEMATIC

RUSCHMEYER
JAH 1995 v.2.

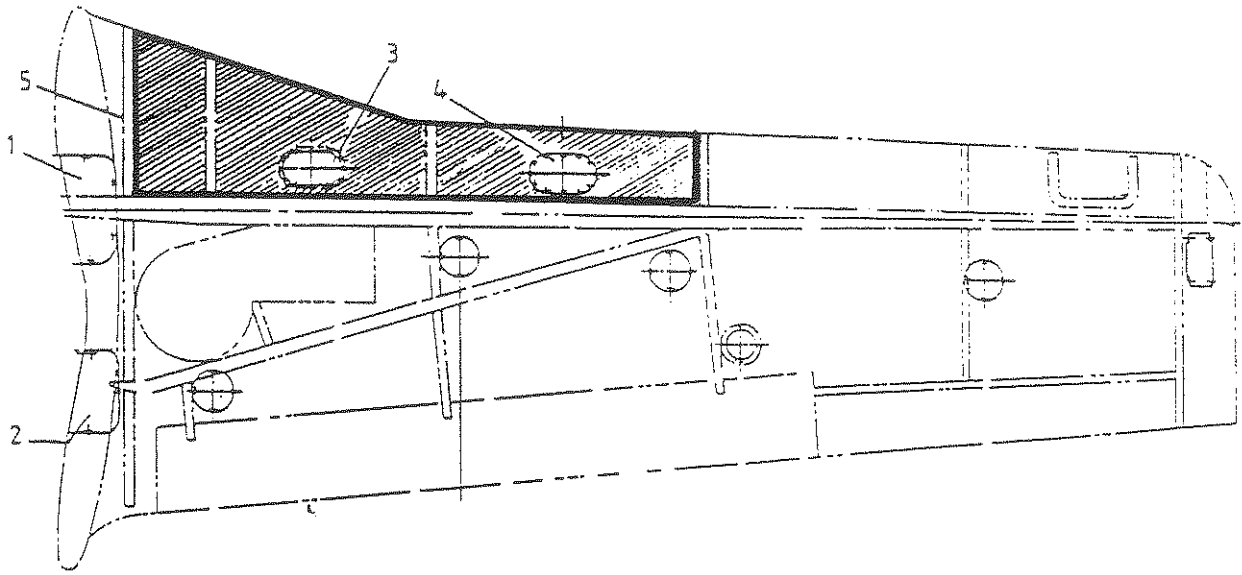
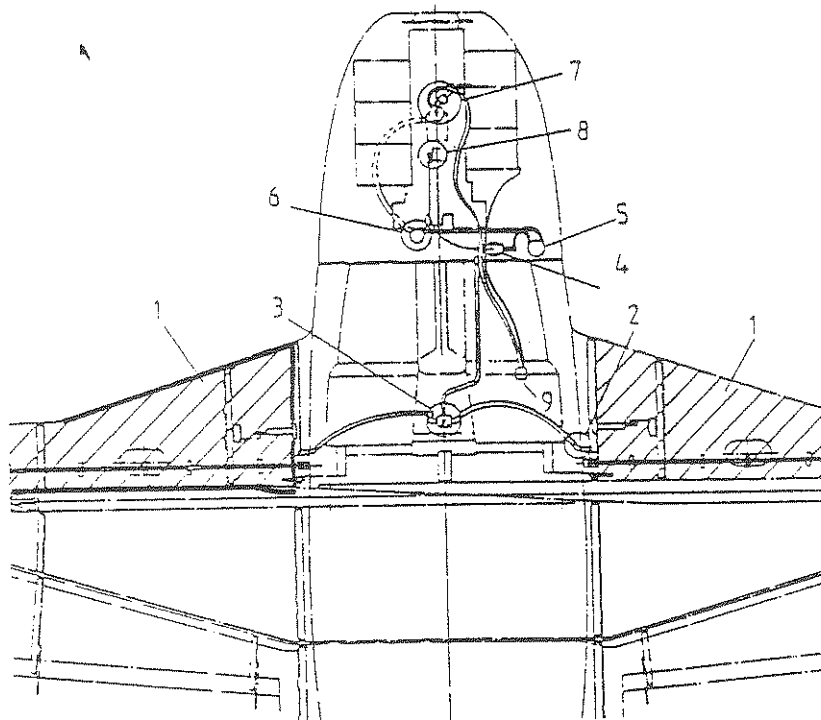

Fig.: 201
Fuel tank and hand hole cover



- | | | |
|---------------------------|--------------------------|--------------------------|
| 1 = fuel tank | 4 = fuel filter | 7 = injection system |
| 2 = tank fitting | 5 = electrical fuel pump | 8 = drain valve actuator |
| 3 = tank selection switch | 6 = mechanical fuel pump | 9 = fuel flow display |

Fig.: 201
Fuel distribution

I. Fuel system

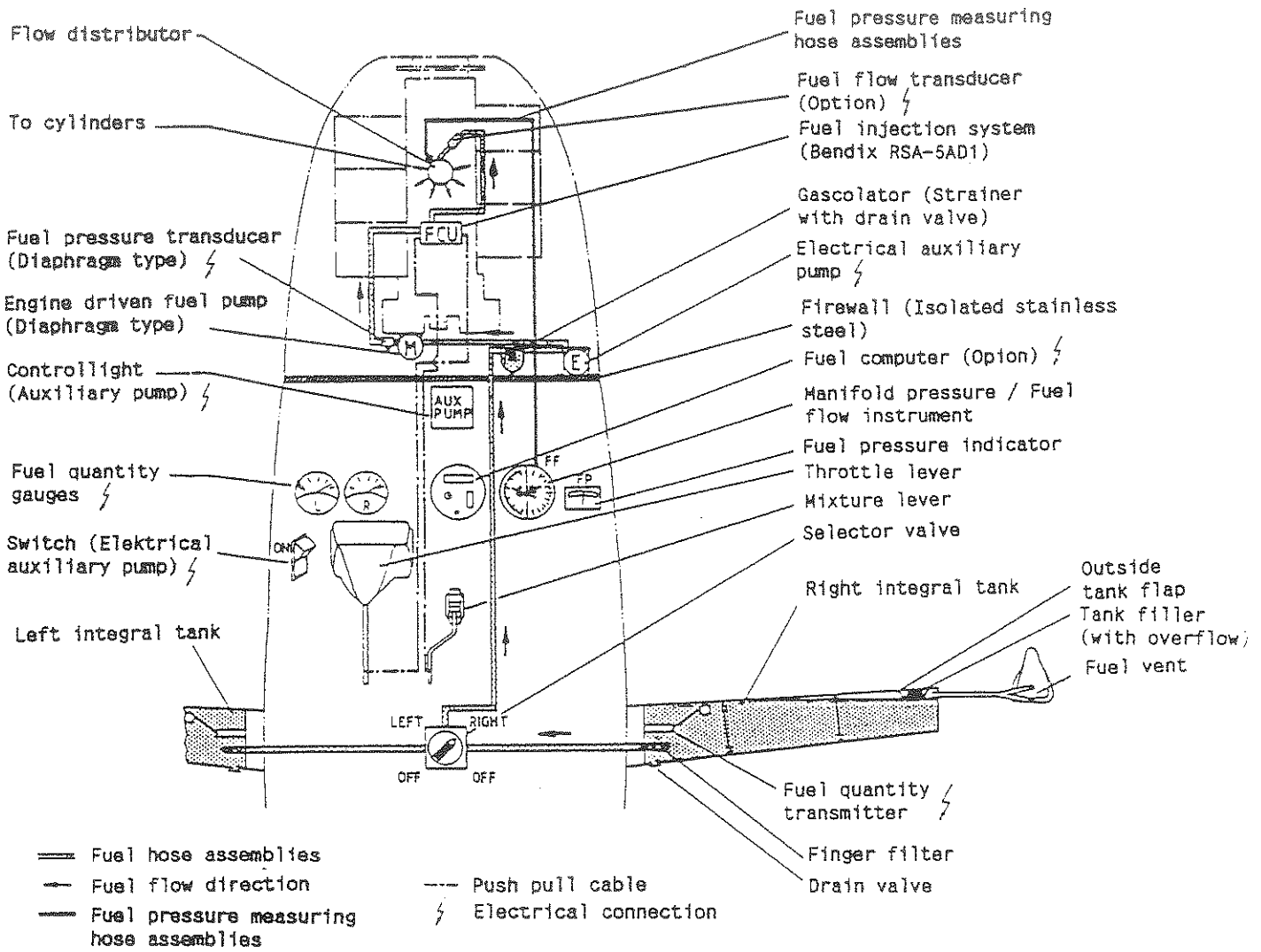
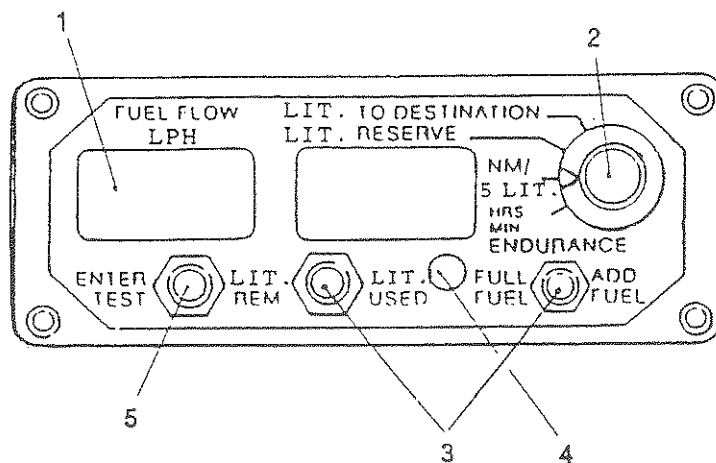
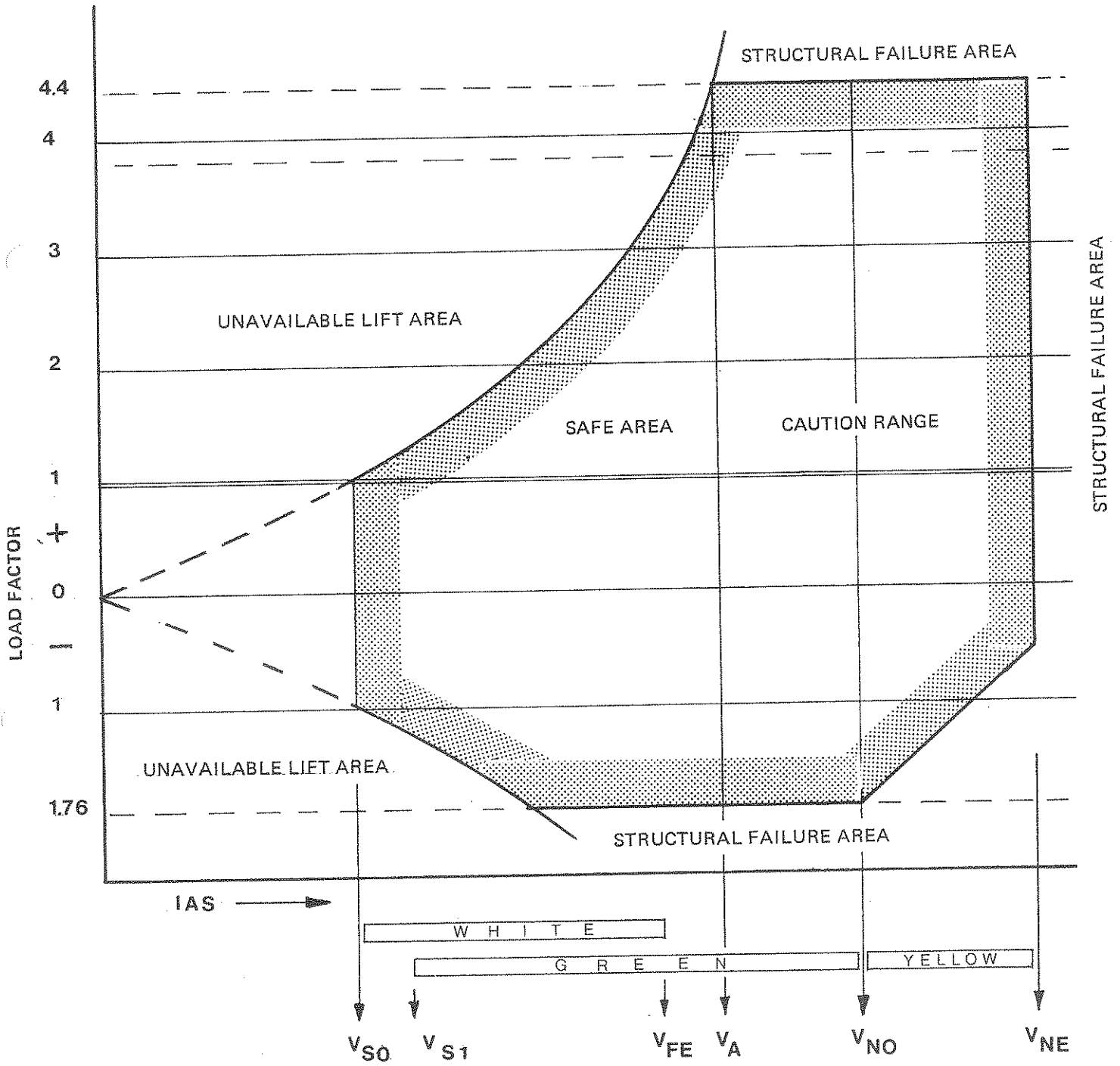

Fig.: 1
Fuel system



- 1 = continuous fuel flow indicator
- 2 = mode selection knob
- 3 = toggle switch
- 4 = photo cell for automatic dimming
- 5 = button

V-n DIAGRAM



Weight & Balance Form

R 90 - 230 - RG

Datum: Call-sign: PH - GWW

Maximum TOW: 1350 Kg

Center of Grav.: Between 2.1976 m and 2.3677 m at 1250 Kg.

	Weight (Kg)		x Arm (Meters)	= Moment
Basic Empty Weight	953.0	x	2.2320	= 2127.1
Pilot + Copilot		x	2.3600	=
Passengers		x	3.2100	=
Baggage (50 Kg max)		x	4.2300	=
Fuel 236 Lx0.72 Kg = 170 Kg		x	2.1000	=
Total Loaded Aircraft		x		=
Maxim. Loaded Aircraft	1350.0	x		=
Change of W & B*:		x		=
New Weight:		x		=
Total Loaded Aircraft		x		=

* Fuel at IAF
 1 USG = 3.7854 L. 1 lbs = 0.4535 Kg.

Best Glide-----V_A-----C.G Range versus Weight

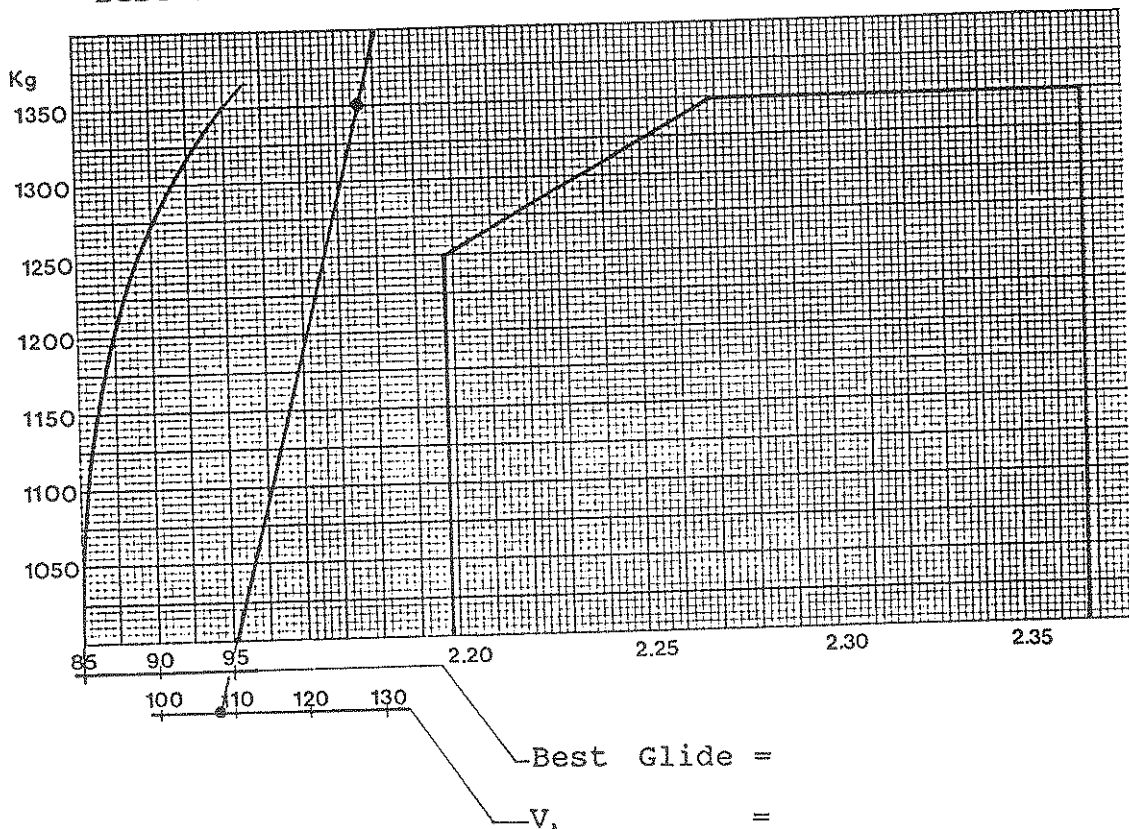

Best Glide =

V_A =